

PAM-16130-SSI

March 31, 2026



PAM-16130-SSI

Determination of 2,3,7,8-Substituted Tetra- through Octa-Chlorinated Dibenzo-*p*-Dioxins and Dibenzofurans (CDDs/CDFs) Using Shimadzu Gas Chromatography Mass Spectrometry (GC-MS/MS)

Revision 2.0

1.0 Scope and Application

- 1.1 This method is for determination of tetra- through octa-chlorinated dibenzo-*p*-dioxins (CDDs) and dibenzofurans (CDFs) in water, soil, sediment, sludge, tissue, and other sample matrices by gas chromatography coupled with a tandem quadrupole mass spectrometry system (GC-MS/MS). The method is for use in EPA's data gathering and monitoring programs associated with the Clean Water Act, the Resource Conservation and Recovery Act, the Comprehensive Environmental Response, Compensation and Liability Act, and the Safe Drinking Water Act. The method is based on a compilation of EPA, industry, commercial laboratory, and academic methods (References 1-6).
- 1.2 The seventeen 2,3,7,8-substituted CDDs/CDFs listed in Table 1 may be determined by this method. Specifications are also provided for separate determination of 2,3,7,8-tetrachloro-dibenzo-*p*-dioxin (2,3,7,8-TCDD) and 2,3,7,8-tetrachloro-dibenzofuran (2,3,7,8-TCDF).
- 1.3 The detection limits and quantitation levels in this method are usually dependent on the level of interferences rather than instrumental limitations. The minimum levels (MLs) in Table 2 are the levels at which the CDDs/CDFs can be determined with no interferences present. The Method Detection Limit (MDL) for 2,3,7,8-TCDD has been determined as 4 pg/L (parts-per-quadrillion) using this method and a Shimadzu TQ-8050NX GC-MS/MS.
- 1.4 The GC-MS/MS portions of this method are for use only by analysts experienced with tandem quadrupole mass spectrometry or under the close supervision of such qualified persons. Each laboratory that uses this method must demonstrate the ability to generate acceptable results using the procedure in Section 9.2.
- 1.5 This method is "performance-based". The analyst is permitted to modify the method to overcome interferences or lower the cost of measurements, provided that all performance criteria in this method are met. The requirements for establishing method equivalency are given in Section 9.1.2. Examples of allowed method modifications are described at 40 CFR 136.6.
- 1.6 Any modification of this method, beyond those expressly allowed at 40 CFR 136.6, shall be considered a major modification subject to application and approval of alternate test procedures under 40 CFR 136.4 and 136.5.

2.0 Summary of Method

Flow charts that summarize procedures for sample preparation, extraction, and analysis are given in Figure 1 for aqueous and solid samples, Figure 2 for multi-phase samples, and Figure 3 for tissue samples.

2.1 Extraction

2.1.1 Aqueous samples (samples containing less than one percent solids)—Stable isotopically labeled analogs of 15 of the 2,3,7,8-substituted CDDs/CDFs are spiked into a one-liter sample, and the sample is extracted by one of three procedures:

2.1.1.1 Samples containing no visible particles are extracted with methylene chloride in a separatory funnel or by the solid-phase extraction technique summarized in Section 2.1.1.3. The extract is concentrated for cleanup.

2.1.1.2 Samples containing visible particles are vacuum filtered through a glass-fiber filter. The filter is extracted in a Soxhlet/Dean-Stark (SDS) extractor (Reference 7), and the filtrate is extracted with methylene chloride in a separatory funnel. The methylene chloride extract is concentrated and combined with the SDS extract prior to cleanup.

2.1.1.3 The sample is vacuum filtered through a glass-fiber filter on top of a solid-phase extraction (SPE) disk. The filter and disk are extracted in an SDS extractor, and the extract is concentrated for cleanup.

2.1.2 Solid, semi-solid, and multi-phase samples (but not tissue)—The labeled compounds are spiked into a sample containing 10 g (dry weight) of solids. Samples containing multiple phases are pressure filtered and any aqueous liquid is discarded. Coarse solids are ground or homogenized. Any non-aqueous liquid from multi-phase samples is combined with the solids and extracted in an SDS extractor. The extract is concentrated for cleanup.

2.1.3 Fish and other tissue —The sample is extracted by one of two procedures:

2.1.3.1 Soxhlet or SDS extraction—A 20-g aliquot of sample is homogenized, and a 10-g aliquot is spiked with the labeled compounds. The sample is mixed with sodium sulfate, allowed to dry for 12-24 hours, and extracted for 18-24 hours using methylene chloride:hexane (1:1) in a Soxhlet extractor. The extract is evaporated to dryness, and the lipid content is determined.

2.1.3.2 HCl digestion—A 20-g aliquot is homogenized, and a 10-g aliquot is placed in a bottle and spiked with the labeled compounds. After equilibration, 200 mL of hydrochloric acid and 200 mL of methylene chloride:hexane (1:1) are added, and the bottle is agitated for 12-24 hours. The extract is evaporated to dryness, and the lipid content is determined.

2.2 After extraction, ³⁷Cl₄-labeled 2,3,7,8-TCDD is added to each extract to measure the efficiency of the cleanup process. Sample cleanups may include back-extraction with acid and/or base, and gel permeation, alumina, silica gel, Florisil and activated carbon chromatography. High-performance liquid chromatography (HPLC) can be used for further isolation of the 2,3,7,8- isomers or other specific isomers or congeners. Prior to the cleanup procedures cited above, tissue extracts are cleaned up using an anthropogenic isolation column, a batch silica gel adsorption, or sulfuric acid and base back-extraction, depending on the tissue extraction procedure used.

- 2.3 After cleanup, the extract is concentrated to near dryness. Immediately prior to injection, internal standards are added to each extract, and an aliquot of the extract is injected into the gas chromatograph. The analytes are separated by the GC and detected by a tandem quadrupole mass spectrometer. Two MRM transitions are monitored for each of the native CDD/CDF analytes and their corresponding ^{13}C -labeled analogues. Two masses from the molecular ion cluster are used as the transition precursors each with its own product ion (loss of COCl).
- 2.4 An individual CDD/CDF is identified by comparing the GC retention time and MRM transition product ion ratio (primary/secondary transition) with the corresponding retention time of an authentic standard and the theoretical transition product ion ratio. The non-2,3,7,8 substituted isomers and congeners are identified when retention times and ion-abundance ratios agree within predefined limits. Isomer specificity for 2,3,7,8-TCDD and 2,3,7,8-TCDF is achieved using GC columns that resolve these isomers from the other tetra-isomers.
- 2.5 Quantitative analysis is performed using MRM transition product ion areas, in one of three ways:
 - 2.5.1 For the fifteen 2,3,7,8-substituted CDDs/CDFs with labeled analogs (see Table 1), the GC-MS/MS system is calibrated, and the concentration of each compound is determined using the isotope dilution technique.
 - 2.5.2 For 1,2,3,7,8,9-HxCDD, OCDF, and the labeled compounds, the GC-MS/MS system is calibrated, and the concentration of each compound is determined using the internal standard technique.
 - 2.5.3 For non-2,3,7,8-substituted isomers and for all isomers at a given level of chlorination (i.e., total TCDD), concentrations are determined using response factors from calibration of the CDDs/CDFs at the same level of chlorination.
- 2.6 The quality of the analysis is assured through reproducible calibration and testing of the extraction, cleanup, and GC-MS/MS as a system.

3.0 Definitions

Definitions are given in the glossary at the end of this method.

4.0 Contamination and Interferences

- 4.1 Solvents, reagents, glassware, and other sample processing hardware may yield artifacts and/or elevated baselines causing misinterpretation of chromatograms (References 8-9). Specific selection of reagents and purification of solvents by distillation in all-glass systems may be required. Where possible, reagents are cleaned by extraction or solvent rinse.
- 4.2 Proper cleaning of glassware is extremely important, because glassware may not only contaminate the samples but may also remove the analytes of interest by adsorption on the glass surface.
 - 4.2.1 Glassware should be rinsed with solvent and washed with a detergent solution as soon after use as is practical. Sonication of glassware containing a detergent solution for approximately 30 seconds may aid in cleaning. Glassware with removable parts, particularly separatory funnels with fluoropolymer stopcocks, must be disassembled prior to detergent washing.

- 4.2.2** After detergent washing, glassware should be rinsed immediately, first with methanol, then with hot tap water. The tap water rinse is followed by another methanol rinse, then acetone, and then methylene chloride.
- 4.2.3** Do not bake reusable glassware in an oven as a routine part of cleaning. Baking may be warranted after particularly dirty samples are encountered but should be minimized, as repeated baking of glassware may cause active sites on the glass surface that will irreversibly adsorb CDDs/CDFs.
- 4.2.4** Immediately prior to use, the Soxhlet apparatus should be pre-extracted with toluene for approximately 3 hours (see Sections 12.3.1-12.3.3). Separatory funnels should be shaken with methylene chloride/toluene (80/20 mixture) for 2 minutes, drained, and then shaken with pure methylene chloride for 2 minutes.
- 4.3** All materials used in the analysis shall be demonstrated to be free from interferences by running reference matrix method blanks initially and with each sample batch (samples started through the extraction process on a given 12-hour shift, to a maximum of 20 samples).
- 4.3.1** The reference matrix must simulate, as closely as possible, the sample matrix under test. Ideally, the reference matrix should not contain the CDDs/CDFs in detectable amounts, but should contain potential interferents in the concentrations expected to be found in the samples to be analyzed. For example, a reference sample of human adipose tissue containing pentachloronaphthalene can be used to exercise the cleanup systems when samples containing pentachloronaphthalene are expected.
- 4.3.2** When a reference matrix that simulates the sample matrix under test is not available, reagent water (Section 7.6.1) can be used to simulate water samples; playground sand (Section 7.6.2) or white quartz sand (Section 7.3.2) can be used to simulate soils; filter paper (Section 7.6.3) can be used to simulate papers and similar materials; and corn oil (Section 7.6.4) can be used to simulate tissues.
- 4.4** Interferences coextracted from samples will vary considerably from source to source, depending on the diversity of the site being sampled. Interfering compounds may be present at concentrations several orders of magnitude higher than the CDDs/CDFs. The most frequently encountered interferences are chlorinated biphenyls, methoxy biphenyls, hydroxydiphenyl ethers, benzylphenyl ethers, polynuclear aromatics, and pesticides. Because very low levels of CDDs/CDFs are measured by this method, the elimination of interferences is essential. The cleanup steps given in Section 13 can be used to reduce or eliminate these interferences and thereby permit reliable determination of the CDDs/CDFs at the levels shown in Table 2.
- 4.5** Each piece of reusable glassware should be numbered to associate that glassware with the processing of a particular sample. This will assist the laboratory in tracking possible sources of contamination for individual samples, identifying glassware associated with highly contaminated samples that may require extra cleaning, and determining when glassware should be discarded.
- 4.6** Cleanup of tissue—The natural lipid content of tissue can interfere in the analysis of tissue samples for the CDDs/CDFs. The lipid contents of different species and portions of tissue can vary widely. Lipids are soluble to varying degrees in various organic solvents and may be present in sufficient quantity to overwhelm the column chromatographic cleanup procedures used for cleanup of sample extracts. Lipids must be removed by the lipid removal procedures in Section 13.7, followed by alumina (Section 13.4) or Florisil (Section 13.8), and carbon (Section 13.5) as minimum additional

cleanup steps. If chlorodiphenyl ethers are detected, as indicated by the presence of peaks in the MRM transitions monitored for these interferents, alumina and/or Florisil cleanup must be employed to eliminate these interferences.

5.0 Safety

- 5.1 The toxicity or carcinogenicity of each compound or reagent used in this method has not been precisely determined; however, each chemical compound should be treated as a potential health hazard. Exposure to these compounds should be reduced to the lowest possible level.
 - 5.1.1 The 2,3,7,8-TCDD isomer has been found to be acnegenic, carcinogenic, and teratogenic in laboratory animal studies. It is soluble in water to approximately 200 ppt and in organic solvents to 0.14%. Based on the available toxicological and physical properties of 2,3,7,8-TCDD, all CDDs/CDFs should be handled only by highly trained personnel thoroughly familiar with handling and cautionary procedures and the associated risks.
 - 5.1.2 It is recommended that the laboratory purchase dilute standard solutions of the analytes in this method. However, if primary solutions are prepared, they shall be prepared in a hood, and a NIOSH/MESA approved toxic gas respirator shall be worn when high concentrations are handled.
- 5.2 The laboratory is responsible for maintaining a current awareness file of OSHA regulations regarding the safe handling of the chemicals specified in this method. A reference file of material safety data sheets (MSDSs) should also be made available to all personnel involved in these analyses. It is also suggested that the laboratory perform personal hygiene monitoring of each analyst who uses this method and that the results of this monitoring be made available to the analyst. Additional information on laboratory safety can be found in References 10-13. The references and bibliography at the end of Reference 13 are particularly comprehensive in dealing with the general subject of laboratory safety.
- 5.3 The CDDs/CDFs and samples suspected to contain these compounds are handled using essentially the same techniques employed in handling radioactive or infectious materials. Well-ventilated, controlled access laboratories are required. Assistance in evaluating the health hazards of particular laboratory conditions may be obtained from certain consulting laboratories and from State Departments of Health or Labor, many of which have an industrial health service. The CDDs/CDFs are extremely toxic to laboratory animals. Each laboratory must develop a strict safety program for handling these compounds. The practices in References 2 and 14 are highly recommended.
 - 5.3.1 Facility—When finely divided samples (dusts, soils, dry chemicals) are handled, all operations (including removal of samples from sample containers, weighing, transferring, and mixing) should be performed in a glove box demonstrated to be leak tight or in a fume hood demonstrated to have adequate air flow. Gross losses to the laboratory ventilation system must not be allowed. Handling of the dilute solutions normally used in analytical and animal work presents no inhalation hazards except in the case of an accident.
 - 5.3.2 Protective equipment—Disposable plastic gloves, apron or lab coat, safety glasses or mask, and a glove box or fume hood adequate for radioactive work should be used. During analytical operations that may give rise to aerosols or dusts, personnel should wear respirators equipped with activated carbon filters. Eye protection equipment (preferably full face shields) must be worn while working with exposed samples or pure analytical standards. Latex gloves are

commonly used to reduce exposure of the hands. When handling samples suspected or known to contain high concentrations of the CDDs/CDFs, an additional set of gloves can also be worn beneath the latex gloves.

- 5.3.3** Training—Workers must be trained in the proper method of removing contaminated gloves and clothing without contacting the exterior surfaces.
- 5.3.4** Personal hygiene—Hands and forearms should be washed thoroughly after each manipulation and before breaks (coffee, lunch, and shift).
- 5.3.5** Confinement—Isolated work areas posted with signs, segregated glassware and tools, and plastic absorbent paper on bench tops will aid in confining contamination.
- 5.3.6** Effluent vapors—The effluents of sample splitters from the gas chromatograph (GC) and from roughing pumps on the mass spectrometer (MS) should pass through either a column of activated charcoal or be bubbled through a trap containing oil or high-boiling alcohols to condense CDD/CDF vapors.
- 5.3.7** Waste Handling—Good technique includes minimizing contaminated waste. Plastic bag liners should be used in waste cans. Janitors and other personnel must be trained in the safe handling of waste.
- 5.3.8** Decontamination.
 - 5.3.8.1** Decontamination of personnel—Use any mild soap with plenty of scrubbing action.
 - 5.3.8.2** Glassware, tools, and surfaces—Chlorothene NU Solvent is the least toxic solvent shown to be effective. Satisfactory cleaning may be accomplished by rinsing with Chlorothene, then washing with any detergent and water. If glassware is first rinsed with solvent, then the dish water may be disposed of in the sewer. Given the cost of disposal, it is prudent to minimize solvent wastes.
- 5.3.9** Laundry—Clothing known to be contaminated should be collected in plastic bags. Persons who convey the bags and launder the clothing should be advised of the hazard and trained in proper handling. The clothing may be put into a washer without contact if the launderer knows of the potential problem. The washer should be run through a cycle before being used again for other clothing.
- 5.3.10** Wipe tests—A useful method of determining cleanliness of work surfaces and tools is to wipe the surface with a piece of filter paper. Extraction and analysis by GC with an electron capture detector (ECD) can achieve a limit of detection of 0.1 µg per wipe; analysis using this method can achieve an even lower detection limit. Less than 0.1 µg per wipe indicates acceptable cleanliness; anything higher warrants further cleaning. More than 10 µg on a wipe constitutes an acute hazard and requires prompt cleaning before further use of the equipment or work space, and indicates that unacceptable work practices have been employed.
- 5.3.11** Table or wrist-action shaker—The use of a table or wrist-action shaker for extraction of tissues presents the possibility of breakage of the extraction bottle and spillage of acid and flammable organic solvent. A secondary containment system around the shaker is suggested to prevent the spread of acid and solvents in the event of such a breakage. The speed and intensity of shaking action should also be adjusted to minimize the possibility of breakage.

6.0 Apparatus and Materials

Note: Brand names, suppliers, and part numbers are for illustration purposes only and no endorsement is implied. Equivalent performance may be achieved using apparatus and materials other than those specified here. Meeting the performance requirements of this method is the responsibility of the laboratory.

6.1 Sampling equipment for discrete or composite sampling.

6.1.1 Sample bottles and caps.

6.1.1.1 Liquid samples (waters, sludges and similar materials containing 5 percent solids or less)—Sample bottle, amber glass, 1.1-L minimum, with screw cap.

6.1.1.2 Solid samples (soils, sediments, sludges, paper pulps, filter cake, compost, and similar materials that contain more than 5 percent solids)—Sample bottle, wide mouth, amber glass, 500-mL minimum.

6.1.1.3 If amber bottles are not available, samples shall be protected from light.

6.1.1.4 Bottle caps—Threaded to fit sample bottles. Caps shall be lined with fluoropolymer.

6.1.1.5 Cleaning.

6.1.1.5.1 Bottles are detergent water washed, then solvent rinsed before use.

6.1.1.5.2 Liners are detergent water washed, rinsed with reagent water (Section 7.6.1) followed by solvent, and baked at approximately 200 °C for a minimum of 1 hour prior to use.

6.1.2 Compositing equipment—Automatic or manual compositing system incorporating glass containers cleaned per bottle cleaning procedure above. Only glass or fluoropolymer tubing shall be used. If the sampler uses a peristaltic pump, a minimum length of compressible silicone rubber tubing may be used in the pump only. Before use, the tubing shall be thoroughly rinsed with methanol, followed by repeated rinsing with reagent water to minimize sample contamination. An integrating flow meter is used to collect proportional composite samples.

6.2 Equipment for glassware cleaning—Laboratory sink with overhead fume hood.

6.3 Equipment for sample preparation.

6.3.1 Laboratory fume hood of sufficient size to contain the sample preparation equipment listed below.

6.3.2 Glove box (optional).

6.3.3 Tissue homogenizer—VirTis Model 45 Macro homogenizer (American Scientific Products H-3515, or equivalent) with stainless steel Macro-shaft and Turbo-shear blade.

6.3.4 Meat grinder—Hobart, or equivalent, with 3- to 5-mm holes in inner plate.

6.3.5 Equipment for determining percent moisture.

6.3.5.1 Oven—Capable of maintaining a temperature of 110 ± 5 °C.

6.3.5.2 Desiccator.

6.3.6 Balances.

6.3.6.1 Analytical—Capable of weighing 0.1 mg.

6.3.6.2 Top loading—Capable of weighing 10 mg.

6.4 Extraction apparatus.

6.4.1 Water samples.

6.4.1.1 pH meter, with combination glass electrode.

6.4.1.2 pH paper, wide range (Hydrion Papers, or equivalent).

6.4.1.3 Graduated cylinder, 1-L capacity.

6.4.1.4 Liquid/liquid extraction—Separatory funnels, 250-, 500-, and 2000-mL, with fluoropolymer stopcocks.

6.4.1.5 Solid-phase extraction.

6.4.1.5.1 1-L filtration apparatus, including glass funnel, glass frit support, clamp, adapter, stopper, filtration flask, and vacuum tubing (Figure 4). For wastewater samples, the apparatus should accept 90- or 144-mm disks. For drinking water or other samples containing low solids, smaller disks may be used.

6.4.1.5.2 Vacuum source capable of maintaining 25 in. Hg, equipped with shutoff valve and vacuum gauge.

6.4.1.5.3 Glass-fiber filter—Whatman GMF 150 (or equivalent), 1 micron pore size, to fit filtration apparatus in Section 6.4.1.5.1.

6.4.1.5.4 Solid-phase extraction disk containing octadecyl (C₁₈) bonded silica uniformly enmeshed in an inert matrix—Fisher Scientific 14-378F (or equivalent), to fit filtration apparatus in Section 6.4.1.5.1.

6.4.2 Soxhlet/Dean-Stark (SDS) extractor (Figure 5) for filters and solid/sludge samples.

6.4.2.1 Soxhlet—50-mm ID, 200-mL capacity with 500-mL flask (Cal-Glass LG-6900, or equivalent, except substitute 500-mL round-bottom flask for 300-mL flat-bottom flask).

6.4.2.2 Thimble—43 × 123 to fit Soxhlet (Cal-Glass LG-6901-122, or equivalent).

6.4.2.3 Moisture trap—Dean Stark or Barret with fluoropolymer stopcock, to fit Soxhlet.

6.4.2.4 Heating mantle—Hemispherical, to fit 500-mL round-bottom flask (Cal-Glass LG-8801-112, or equivalent).

6.4.2.5 Variable transformer—Powerstat (or equivalent), 110-volt, 10-amp.

6.4.3 Apparatus for extraction of tissue.

6.4.3.1 Bottle for extraction (if digestion/ extraction using HCl is used)—500- to 600-mL wide-mouth clear glass, with fluoropolymer-lined cap.

6.4.3.2 Bottle for back-extraction—100- to 200-mL narrow-mouth clear glass with fluoropolymer-lined cap.

- 6.4.3.3** Mechanical shaker—Wrist-action or platform-type rotary shaker that produces vigorous agitation (Sybron Thermolyne Model LE "Big Bill" rotator/shaker, or equivalent).
- 6.4.3.4** Rack attached to shaker table to permit agitation of 4-9 samples simultaneously.
- 6.4.4** Beakers—400- to 500-mL.
- 6.4.5** Spatulas—Stainless steel.
- 6.5 Filtration apparatus.
 - 6.5.1** Pyrex glass wool—Solvent-extracted by SDS for 3 hours minimum.

Note: Baking glass wool may cause active sites that irreversibly adsorb CDDs/CDFs.

- 6.5.2** Glass funnel—125- to 250-mL.
- 6.5.3** Glass-fiber filter paper—Whatman™ GF/D (or equivalent), to fit glass funnel in Section 6.5.2.
- 6.5.4** Drying column—15- to 20-mm ID Pyrex chromatographic column equipped with coarse-glass frit or glass-wool plug.
- 6.5.5** Buchner funnel—15-cm.
- 6.5.6** Glass-fiber filter paper—to fit Buchner funnel in Section 6.5.5.
- 6.5.7** Filtration flasks—1.5- to 2.0-L, with side arm.
- 6.5.8** Pressure filtration apparatus—Millipore YT30 142 HW, or equivalent.
- 6.6 Centrifuge apparatus.
 - 6.6.1** Centrifuge—Capable of rotating 500-mL centrifuge bottles or 15-mL centrifuge tubes at 5,000 rpm minimum.
 - 6.6.2** Centrifuge bottles—500-mL, with screw-caps, to fit centrifuge.
 - 6.6.3** Centrifuge tubes—12- to 15-mL, with screw-caps, to fit centrifuge.
- 6.7 Cleanup apparatus.
 - 6.7.1** Automated gel permeation chromatograph (Analytical Biochemical Labs, Inc, Columbia, MO, Model GPC Autoprep 1002, or equivalent).
 - 6.7.1.1** Column—600-700 mm long × 25 mm ID, packed with 70 g of SX-3 Bio-beads (Bio-Rad Laboratories, Richmond, CA, or equivalent).
 - 6.7.1.2** Syringe—10-mL, with Luer fitting.
 - 6.7.1.3** Syringe filter holder—stainless steel, and glass- fiber or fluoropolymer filters (Gelman 4310, or equivalent).
 - 6.7.1.4** UV detectors—254-nm, preparative or semi-preparative flow cell (Isco, Inc., Type 6; Shimadzu, 5-mm path length; Beckman-Altex 152W, 8-μL micro-prep flow cell, 2-mm path; Pharmacia UV-1, 3-mm flow cell; LDC Milton-Roy UV-3, monitor #1203; or equivalent).

6.7.2 Reverse-phase high-performance liquid chromatograph.

6.7.2.1 Column oven and detector—Perkin-Elmer Model LC-65T (or equivalent) operated at 0.02 AUFS at 235 nm.

6.7.2.2 Injector—Rheodyne 7120 (or equivalent) with 50- μ L sample loop.

6.7.2.3 Column—Two 6.2 mm \times 250 mm Zorbax-ODS columns in series (DuPont Instruments Division, Wilmington, DE, or equivalent), operated at 50 °C with 2.0 mL/min methanol isocratic effluent.

6.7.2.4 Pump—Altex 110A (or equivalent).

6.7.3 Pipets.

6.7.3.1 Disposable, Pasteur, 150-mm long \times 5-mm ID (Fisher Scientific 13-678-6A, or equivalent).

6.7.3.2 Disposable, serological, 10-mL (6-mm ID).

6.7.4 Glass chromatographic columns.

6.7.4.1 150-mm long \times 8-mm ID, (Kontes K-420155, or equivalent) with coarse-glass frit or glass-wool plug and 250-mL reservoir.

6.7.4.2 200-mm long \times 15-mm ID, with coarse-glass frit or glass-wool plug and 250-mL reservoir.

6.7.4.3 300-mm long \times 25-mm ID, with 300-mL reservoir and glass or fluoropolymer stopcock.

6.7.5 Stirring apparatus for batch silica cleanup of tissue extracts.

6.7.5.1 Mechanical stirrer—Corning Model 320, or equivalent.

6.7.5.2 Bottle—500- to 600-mL wide-mouth clear glass.

6.7.6 Oven—For baking and storage of adsorbents, capable of maintaining a constant temperature (± 5 °C) in the range of 105-250 °C.

6.8 Concentration apparatus.

6.8.1 Rotary evaporator—Buchi/Brinkman-American Scientific No. E5045-10 or equivalent, equipped with a variable temperature water bath.

6.8.1.1 Vacuum source for rotary evaporator equipped with shutoff valve at the evaporator and vacuum gauge.

6.8.1.2 A recirculating water pump and chiller are recommended because the use of tap water for cooling the evaporator wastes large volumes of water and can lead to inconsistent performance as water temperatures and pressures vary.

6.8.1.3 Round-bottom flask—100-mL and 500-mL or larger, with ground-glass fitting compatible with the rotary evaporator.

6.8.2 Kuderna-Danish (K-D) concentrator.

7.0 Reagents and Standards

7.1 pH adjustment and back-extraction.

7.1.1 Potassium hydroxide—Dissolve 20 g reagent grade KOH in 100 mL reagent water.

7.1.2 Sulfuric acid—Reagent grade (specific gravity 1.84).

7.1.3 Hydrochloric acid—Reagent grade, 6N.

7.1.4 Sodium chloride—Reagent grade, prepare at 5% (w/v) solution in reagent water.

7.2 Solution drying and evaporation.

7.2.1 Solution drying—Sodium sulfate, reagent grade, granular, anhydrous (Baker 3375, or equivalent), rinsed with methylene chloride (20 mL/g), baked at 400 °C for 1 hour minimum, cooled in a desiccator, and stored in a pre-cleaned glass bottle with screw-cap that prevents moisture from entering. If, after heating, the sodium sulfate develops a noticeable grayish cast (due to the presence of carbon in the crystal matrix), that batch of reagent is not suitable for use and should be discarded. Extraction with methylene chloride (as opposed to simple rinsing) and baking at a lower temperature may produce sodium sulfate that is suitable for use.

7.2.2 Tissue drying—Sodium sulfate, reagent grade, powdered, treated and stored as above.

7.2.3 Pre-purified nitrogen.

7.3 Extraction.

7.3.1 Solvents—Acetone, toluene, cyclohexane, hexane, methanol, methylene chloride, and nonane; distilled in glass, pesticide quality, lot-certified to be free of interferences.

7.3.2 White quartz sand, 60/70 mesh—For Soxhlet/Dean-Stark extraction (Aldrich Chemical, Cat. No. 27-437-9, or equivalent). Bake at 450 °C for 4 hours minimum.

7.4 GPC calibration solution—Prepare a solution containing 300 mg/mL corn oil, 15 mg/mL bis(2-ethylhexyl) phthalate, 1.4 mg/mL pentachlorophenol, 0.1 mg/mL perylene, and 0.5 mg/mL sulfur.

7.5 Adsorbents for sample cleanup.

7.5.1 Silica gel.

7.5.1.1 Activated silica gel—100-200 mesh, Supelco 1-3651 (or equivalent), rinsed with methylene chloride, baked at 180 °C for a minimum of 1 hour, cooled in a desiccator, and stored in a pre-cleaned glass bottle with screw-cap that prevents moisture from entering.

7.5.1.2 Acid silica gel (30% w/w)—Thoroughly mix 44.0 g of concentrated sulfuric acid with 100.0 g of activated silica gel in a clean container. Break up aggregates with a stirring rod until a uniform mixture is obtained. Store in a bottle with a fluoropolymer-lined screw-cap.

7.5.1.3 Basic silica gel—Thoroughly mix 30 g of 1 N sodium hydroxide with 100 g of activated silica gel in a clean container. Break up aggregates with a stirring rod until a uniform mixture is obtained. Store in a bottle with a fluoropolymer-lined screw-cap.

7.5.1.4 Potassium silicate.

7.5.1.4.1 Dissolve 56 g of high purity potassium hydroxide (Aldrich, or equivalent) in 300 mL of methanol in a 750- to 1000-mL flat-bottom flask.

7.5.1.4.2 Add 100 g of silica gel and a stirring bar, and stir on a hot plate at 60-70 °C for 1-2 hours.

7.5.1.4.3 Decant the liquid and rinse the potassium silicate twice with 100-mL portions of methanol, followed by a single rinse with 100 mL of methylene chloride.

7.5.1.4.4 Spread the potassium silicate on solvent-rinsed aluminum foil and dry for 2-4 hours in a hood.

7.5.1.4.5 Activate overnight at 200-250 °C.

7.5.2 Alumina—Either one of two types of alumina, acid or basic, may be used in the cleanup of sample extracts, provided that the laboratory can meet the performance specifications for the recovery of labeled compounds described in Section 9.3. The same type of alumina must be used for all samples, including those used to demonstrate initial precision and recovery (Section 9.2) and ongoing precision and recovery (Section 15.5).

7.5.2.1 Acid alumina—Supelco 19996-6C (or equivalent). Activate by heating to 130 °C for a minimum of 12 hours.

7.5.2.2 Basic alumina—Supelco 19944-6C (or equivalent). Activate by heating to 600 °C for a minimum of 24 hours. Alternatively, activate by heating in a tube furnace at 650 to 700 °C under an air flow rate of approximately 400 cc/minute. Do not heat over 700 °C, as this can lead to reduced capacity for retaining the analytes. Store at 130 °C in a covered flask. Use within five days of baking.

7.5.3 Carbon.

7.5.3.1 Carbopak CTM—(Supelco 1-0258, or equivalent).

7.5.3.2 Celite® 545—(Supelco 2-0199, or equivalent).

7.5.3.3 Thoroughly mix 9.0 g Carbopak C and 41.0 g Celite 545 to produce an 18% w/w mixture. Activate the mixture at 130°C for a minimum of 6 hours. Store in a desiccator.

7.5.4 Anthropogenic isolation column—Pack the column in Section 6.7.4.3 from bottom to top with the following:

7.5.4.1 2 g silica gel (Section 7.5.1.1).

7.5.4.2 2 g potassium silicate (Section 7.5.1.4).

7.5.4.3 2 g granular anhydrous sodium sulfate (Section 7.2.1).

7.5.4.4 10 g acid silica gel (Section 7.5.1.2).

7.5.4.5 2 g granular anhydrous sodium sulfate.

7.5.5 Florisil column

7.5.5.1 Florisil—60-100 mesh, Floridin Corp (or equivalent). Soxhlet extract in 500-g portions for 24 hours.

- 7.5.5.2** Insert a glass wool plug into the tapered end of a graduated serological pipet (Section 6.7.3.2). Pack with 1.5 g (~2 mL) of Florisil topped with approximately 1 mL of sodium sulfate (Section 7.2.1) and a glass wool plug.
- 7.5.5.3** Activate in an oven at 130-150 °C for a minimum of 24 hours and cool for 30 minutes. Use within 90 minutes of cooling.
- 7.6 Reference matrices—Matrices in which the CDDs/CDFs and interfering compounds are not detected by this method.
- 7.6.1** Reagent water—Bottled water purchased locally, or prepared by passage through activated carbon.
- 7.6.2** High-solids reference matrix—Playground sand or similar material. Prepared by extraction with methylene chloride and/or baking at 450 °C for a minimum of 4 hours.
- 7.6.3** Paper reference matrix—Glass-fiber filter, Gelman type A, or equivalent. Cut paper to simulate the surface area of the paper sample being tested.
- 7.6.4** Tissue reference matrix—Corn or other vegetable oil. May be prepared by extraction with methylene chloride.
- 7.6.5** Other matrices—This method may be verified on any reference matrix by performing the tests given in Section 9.2. Ideally, the matrix should be free of the CDDs/CDFs, but in no case shall the background level of the CDDs/CDFs in the reference matrix exceed three times the minimum levels in Table 2. If low background levels of the CDDs/CDFs are present in the reference matrix, the spike level of the analytes used in Section 9.2 should be increased to provide a spike-to-background ratio in the range of 1:1 to 5:1 (Reference 15).
- 7.7 Standard solutions—Purchased as solutions or mixtures with certification to their purity, concentration, and authenticity, or prepared from materials of known purity and composition. If the chemical purity is 98% or greater, the weight may be used without correction to compute the concentration of the standard. When not being used, standards are stored in the dark at room temperature in screw-capped vials with fluoropolymer-lined caps. A mark is placed on the vial at the level of the solution so that solvent loss by evaporation can be detected. If solvent loss has occurred, the solution should be replaced.
- 7.8 Stock solutions.
- 7.8.1** Preparation—Prepare in nonane per the steps below or purchase as dilute solutions (Cambridge Isotope Laboratories (CIL), Woburn, MA, or equivalent). Observe the safety precautions in Section 5 and the recommendation in Section 5.1.2.
- 7.8.2** Dissolve an appropriate amount of assayed reference material in solvent. For example, weigh 1 to 2 mg of 2,3,7,8-TCDD to three significant figures in a 10-mL ground-glass-stoppered volumetric flask and fill to the mark with nonane. After the TCDD is completely dissolved, transfer the solution to a clean 15-mL vial with fluoropolymer-lined cap.
- 7.8.3** Stock standard solutions should be checked for signs of degradation prior to the preparation of calibration or performance test standards. Reference standards that can be used to determine the accuracy of calibration standards are available from CIL and may be available from other vendors.

- 7.9 PAR stock solution.
- 7.9.1** All CDDs/CDFs—Using the solutions in Section 7.8, prepare the PAR stock solution to contain the CDDs/CDFs at the concentrations shown in Table 3. When diluted, the solution becomes the PAR (Section 7.14).
- 7.9.2** If only 2,3,7,8-TCDD and 2,3,7,8-TCDF are to be determined, prepare the PAR stock solution to contain these compounds only.
- 7.10 Labeled-compound spiking solution.
- 7.10.1** All CDDs/CDFs—From stock solutions, or from purchased mixtures, prepare this solution to contain the labeled compounds in nonane at the concentrations shown in Table 3. This solution is diluted with acetone prior to use (Section 7.10.3).
- 7.10.2** If only 2,3,7,8-TCDD and 2,3,7,8-TCDF are to be determined, prepare the labeled-compound solution to contain these compounds only. This solution is diluted with acetone prior to use (Section 7.10.3).
- 7.10.3** Dilute a sufficient volume of the labeled compound solution (Section 7.10.1 or 7.10.2) by a factor of 50 with acetone to prepare a diluted spiking solution. Each sample requires 1.0 mL of the diluted solution, but no more solution should be prepared than can be used in one day.
- 7.11 Cleanup standard—Prepare $^{37}\text{Cl}_4$ -2,3,7,8-TCDD in nonane at the concentration shown in Table 3. The cleanup standard is added to all extracts prior to cleanup to measure the efficiency of the cleanup process.
- 7.12 Internal standard(s).
- 7.12.1** All CDDs/CDFs—Prepare the internal standard solution to contain $^{13}\text{C}_{12}$ -1,2,3,4-TCDD and $^{13}\text{C}_{12}$ -1,2,3,7,8,9-HxCDD in nonane at the concentration shown in Table 3.
- 7.12.2** If only 2,3,7,8-TCDD and 2,3,7,8-TCDF are to be determined, prepare the internal standard solution to contain $^{13}\text{C}_{12}$ -1,2,3,4-TCDD only.
- 7.13 Calibration standards (CS1 through CS5)—Combine the solutions in Sections 7.9-7.12 to produce the five calibration solutions in nonane shown in Table 4. These solutions permit the relative response (labeled to native) and response factor to be measured as a function of concentration. The CS3 standard is used for calibration verification (VER). If only 2,3,7,8-TCDD and 2,3,7,8-TCDF are to be determined, combine the solutions appropriate to these compounds.
- 7.14 Precision and recovery (PAR) standard—Used for determination of initial (Section 9.2) and ongoing (Section 15.5) precision and recovery. Dilute 10 μL of the precision and recovery standard (Section 7.9.1 or 7.9.2) to 2.0 mL with acetone for each sample matrix for each sample batch. One mL each are required for the blank and OPR with each matrix in each batch.
- 7.15 GC retention time window defining solution and isomer specificity test standard—Used to define the beginning and ending retention times for the dioxin and furan isomers and to demonstrate isomer specificity of the GC columns employed for determination of 2,3,7,8-TCDD and 2,3,7,8-TCDF. The standard must contain the compounds listed in Table 5 (CIL EDF-4006, or equivalent), at a minimum. It is not necessary to monitor the window-defining compounds if only 2,3,7,8-TCDD and 2,3,7,8-TCDF are to be determined. In this case, an isomer-specificity test standard containing the most closely eluted isomers listed in Table 5 (CIL EDF-4033, or equivalent) may be used.

- 7.16 QC Check Sample—A QC Check Sample should be obtained from a source independent of the calibration standards. Ideally, this check sample would be a certified reference material containing the CDDs/CDFs in known concentrations in a sample matrix similar to the matrix under test.
- 7.17 Stability of solutions—Standard solutions used for quantitative purposes (Sections 7.9 through 7.15) should be analyzed periodically, and should be assayed against reference standards (Section 7.8.3) before further use.

8.0 Sample Collection, Preservation, Storage, and Holding Times.

- 8.1 Collect samples in amber glass containers following conventional sampling practices (Reference 16). Aqueous samples that flow freely are collected in refrigerated bottles using automatic sampling equipment. Solid samples are collected as grab samples using wide-mouth jars.
- 8.2 Maintain aqueous samples in the dark at 0-4 °C from the time of collection until receipt at the laboratory. If residual chlorine is present in aqueous samples, add 80 mg sodium thiosulfate per liter of water. EPA Methods 330.4 and 330.5 may be used to measure residual chlorine (Reference 17). If the sample pH is greater than 9, adjust to pH 7-9 with sulfuric acid.

Maintain solid, semi-solid, oily, and mixed-phase samples in the dark at <4 °C from the time of collection until receipt at the laboratory.

Store aqueous samples in the dark at 0-4 °C. Store solid, semi-solid, oily, mixed-phase, and tissue samples in the dark at <-10 °C.

- 8.3 Fish and tissue samples.
- 8.3.1** Fish may be cleaned, filleted, or processed in other ways in the field, such that the laboratory may expect to receive whole fish, fish fillets, or other tissues for analysis.
- 8.3.2** Fish collected in the field should be wrapped in aluminum foil, and must be maintained at a temperature less than 4 °C from the time of collection until receipt at the laboratory.
- 8.3.3** Samples must be frozen upon receipt at the laboratory and maintained in the dark at <-10 °C until prepared. Maintain unused sample in the dark at <-10 °C.
- 8.4 Holding times.
- 8.4.1** There are no demonstrated maximum holding times associated with CDDs/CDFs in aqueous, solid, semi-solid, tissues, or other sample matrices. If stored in the dark at 0-4 °C and preserved as given above (if required), aqueous samples may be stored for up to one year. Similarly, if stored in the dark at <-10 °C, solid, semi-solid, multi-phase, and tissue samples may be stored for up to one year.
- 8.4.2** Store sample extracts in the dark at <-10°C until analyzed. If stored in the dark at <-10 °C, sample extracts may be stored for up to one year.

9.0 Quality Assurance/Quality Control

- 9.1 Each laboratory that uses this method is required to operate a formal quality assurance program (Reference 18). The minimum requirements of this program consist of an initial demonstration of

laboratory capability, analysis of samples spiked with labeled compounds to evaluate and document data quality, and analysis of standards and blanks as tests of continued performance. Laboratory performance is compared to established performance criteria to determine if the results of analyses meet the performance characteristics of the method.

If the method is to be applied to sample matrix other than water (e.g., soils, filter cake, compost, tissue) the most appropriate alternate matrix (Sections 7.6.2-7.6.5) is substituted for the reagent water matrix (Section 7.6.1) in all performance tests.

9.1.1 The analyst shall make an initial demonstration of the ability to generate acceptable accuracy and precision with this method. This ability is established as described in Section 9.2.

9.1.2 In recognition of advances that are occurring in analytical technology, and to allow the analyst to overcome sample matrix interferences, the analyst is permitted certain options to improve separations or lower the costs of measurements. These options include alternate extraction, concentration, cleanup procedures, and changes in columns and detectors. Alternate determinative techniques, such as the substitution of spectroscopic or immuno-assay techniques, and changes that degrade method performance, are not allowed. If an analytical technique other than the techniques specified in this method is used, that technique must have a specificity equal to or better than the specificity of the techniques in this method for the analytes of interest.

9.1.2.1 Each time a modification is made to this method, the analyst is required to repeat the procedure in Section 9.2. If the detection limit of the method will be affected by the change, the laboratory is required to demonstrate that the MDL (40 CFR Part 136, Appendix B) is lower than one-third the regulatory compliance level or one-third the ML in this method, whichever is higher. If calibration will be affected by the change, the analyst must recalibrate the instrument per Section 10.

9.1.2.2 The laboratory is required to maintain records of modifications made to this method. These records include the following, at a minimum:

9.1.2.2.1 The names, titles, addresses, and telephone numbers of the analyst(s) who performed the analyses and modification, and of the quality control officer who witnessed and will verify the analyses and modifications.

9.1.2.2.2 A listing of pollutant(s) measured, by name and CAS Registry number.

9.1.2.2.3 A narrative stating reason(s) for the modifications.

9.1.2.2.4 Results from all quality control (QC) tests comparing the modified method to this method, including:

- a) Calibration (Section 10.5-10.7).
- b) Calibration verification (Section 15.3).
- c) Initial precision and recovery (Section 9.2).
- d) Labeled compound recovery (Section 9.3).
- e) Analysis of blanks (Section 9.5).
- f) Accuracy assessment (Section 9.4).

9.1.2.2.5 Data that allow an independent reviewer to validate each determination by tracing the instrument output (peak height, area, or other signal) to the final result. These data are to include:

- a) Sample numbers and other identifiers.
- b) Extraction dates.
- c) Analysis dates and times.
- d) Analysis sequence/run chronology.
- e) Sample weight or volume (Section 11).
- f) Extract volume prior to each cleanup step (Section 13).
- g) Extract volume after each cleanup step (Section 13).
- h) Final extract volume prior to injection (Section 14).
- i) Injection volume (Section 14.3).
- j) Dilution data, differentiating between dilution of a sample or extract (Section 17.5).
- k) Instrument and operating conditions.
- l) Column (dimensions, liquid phase, solid support, film thickness, etc.).
- m) Operating conditions (temperatures, temperature program, flow rates).
- n) Detector (type, operating conditions, etc.).
- o) Chromatograms, printer tapes, and other recordings of raw data.
- p) Quantitation reports, data system outputs, and other data to link the raw data to the results reported.

9.1.3 Analyses of method blanks are required to demonstrate freedom from contamination (Section 4.3). The procedures and criteria for analysis of a method blank are described in Sections 9.5 and 15.6.

9.1.4 The laboratory shall spike all samples with labeled compounds to monitor method performance. This test is described in Section 9.3. When results of these spikes indicate atypical method performance for samples, the samples are diluted to bring method performance within acceptable limits. Procedures for dilution are given in Section 17.5.

9.1.5 The laboratory shall, on an ongoing basis, demonstrate through calibration verification and the analysis of the ongoing precision and recovery aliquot that the analytical system is in control. These procedures are described in Sections 15.1 through 15.5.

9.1.6 The laboratory shall maintain records to define the quality of data that is generated. Development of accuracy statements is described in Section 9.4.

9.2 Initial precision and recovery (IPR)—To establish the ability to generate acceptable precision and recovery, the analyst shall perform the following operations.

9.2.1 For low solids (aqueous) samples, extract, concentrate, and analyze four 1-L aliquots of reagent water spiked with the diluted labeled compound spiking solution (Section 7.10.3) and the

- precision and recovery standard (Section 7.14) according to the procedures in Sections 11 through 18. For an alternative sample matrix, four aliquots of the alternative reference matrix (Section 7.6) are used. All sample processing steps that are to be used for processing samples, including preparation (Section 11), extraction (Section 12), and cleanup (Section 13), shall be included in this test.
- 9.2.2** Using results of the set of four analyses, compute the average concentration (X) of the extracts in ng/mL and the standard deviation of the concentration (s) in ng/mL for each compound, by isotope dilution for CDDs/CDFs with a labeled analog, and by internal standard for 1,2,3,7,8,9-HxCDD, OCDF, and the labeled compounds.
- 9.2.3** For each CDD/CDF and labeled compound, compare s and X with the corresponding limits for initial precision and recovery in Table 6. If only 2,3,7,8-TCDD and 2,3,7,8-TCDF are to be determined, compare s and X with the corresponding limits for initial precision and recovery in Table 6a. If s and X for all compounds meet the acceptance criteria, system performance is acceptable and analysis of blanks and samples may begin. If, however, any individual s exceeds the precision limit or any individual X falls outside the range for accuracy, system performance is unacceptable for that compound. Correct the problem and repeat the test (Section 9.2).
- 9.3 The laboratory shall spike all samples with the diluted labeled compound spiking solution (Section 7.10.3) to assess method performance on the sample matrix.
- 9.3.1** Analyze each sample according to the procedures in Sections 11 through 18.
- 9.3.2** Compute the percent recovery of the labeled compounds and the cleanup standard using the internal standard method (Section 17.2).
- 9.3.3** The recovery of each labeled compound must be within the limits in Table 7 when all 2,3,7,8-substituted CDDs/CDFs are determined, and within the limits in Table 7a when only 2,3,7,8-TCDD and 2,3,7,8-TCDF are determined. If the recovery of any compound falls outside of these limits, method performance is unacceptable for that compound in that sample. To overcome such difficulties, water samples are diluted and smaller amounts of soils, sludges, sediments, and other matrices are reanalyzed per Section 18.4.
- 9.4 Recovery of labeled compounds from samples should be assessed and records should be maintained.
- 9.4.1** After the analysis of five samples of a given matrix type (water, soil, sludge, pulp, etc.) for which the labeled compounds pass the tests in Section 9.3, compute the average percent recovery (R) and the standard deviation of the percent recovery (s_R) for the labeled compounds only. Express the assessment as a percent recovery interval from $R - 2s_R$ to $R + 2s_R$ for each matrix. For example, if $R = 90\%$ and $s_R = 10\%$ for five analyses of pulp, the recovery interval is expressed as 70 to 110%.
- 9.4.2** Update the accuracy assessment for each labeled compound in each matrix on a regular basis (e.g., after each five to ten new measurements).
- 9.5 Method blanks—Reference matrix method blanks are analyzed to demonstrate freedom from contamination (Section 4.3).
- 9.5.1** Prepare, extract, clean up, and concentrate a method blank with each sample batch (samples of the same matrix started through the extraction process on the same 12-hour shift, to a maximum of 20 samples). The matrix for the method blank shall be similar to sample matrix for the batch, e.g., a 1-L reagent water blank (Section 7.6.1), high-solids reference matrix blank (Section

7.6.2), paper matrix blank (Section 7.6.3); tissue blank (Section 7.6.4) or alternative reference matrix blank (Section 7.6.5). Analyze the blank immediately after analysis of the OPR (Section 15.5) to demonstrate freedom from contamination.

- 9.5.2** If any 2,3,7,8-substituted CDD/CDF (Table 1) is found in the blank at greater than the minimum level (Table 2) or one-third the regulatory compliance level, whichever is greater; or if any potentially interfering compound is found in the blank at the minimum level for each level of chlorination given in Table 2 (assuming a response factor of 1 relative to the $^{13}\text{C}_{12}$ -1,2,3,4-TCDD internal standard for compounds not listed in Table 1), analysis of samples is halted until the blank associated with the sample batch shows no evidence of contamination at this level. All samples must be associated with an uncontaminated method blank before the results for those samples may be reported for regulatory compliance purposes.
- 9.6 QC Check Sample—Analyze the QC Check Sample (Section 7.16) periodically to assure the accuracy of calibration standards and the overall reliability of the analytical process. It is suggested that the QC Check Sample be analyzed at least quarterly.
- 9.7 The specifications contained in this method can be met if the apparatus used is calibrated properly and then maintained in a calibrated state. The standards used for calibration (Section 10), calibration verification (Section 15.3), and for initial (Section 9.2) and ongoing (Section 15.5) precision and recovery should be identical, so that the most precise results will be obtained. A GC-MS/MS instrument dedicated to the settings and conditions required for the analyses of CDDs/CDFs by this method provides the most reproducible results.
- 9.8 Depending on specific program requirements, field replicates may be collected to determine the precision of the sampling technique, and spiked samples may be required to determine the accuracy of the analysis when the internal standard method is used.

10.0 Calibration

- 10.1 Establish the operating conditions necessary to meet the minimum retention times for the internal standards in Section 10.2.4 and the relative retention times for the CDDs/CDFs in Table 2.

10.1.1 Suggested GC operating conditions:

Injector temperature:	290 °C
Interface temperature:	300 °C
Initial temperature:	150 °C
Initial time:	2 minutes
Temperature program:	200 to 220 °C, at 5 °C/minute 220 °C for 16 minutes 220 to 235°C, at 5 °C/minute 235 °C for 7/minutes 235 to 330 °C, at 5 °C/minute

Note: All portions of the column that connect the GC to the ion source shall remain at or above the interface temperature specified above during analysis to preclude condensation of less volatile compounds.

Alternate temperature programs can be employed. Optimize GC conditions for compound separation and sensitivity. Once optimized, the same GC conditions must be used for the analysis of all standards, blanks, IPR and OPR aliquots, and samples.

10.1.2 Mass spectrometer (MS/MS) resolution—Monitor the two MRM transitions specified in Table 8 for each analyte in Table 3 by injecting an authentic standard of the CDDs/CDFs either singly or as part of a mixture in which there is no interference between closely eluted components.

10.1.2.1 In a temperature-controlled laboratory the long-term mass stability of the mass spectrometer is not a critical parameter when using quadrupole-based tandem mass spectrometry, so there is no need to monitor mass control throughout the analytical run. However, the signal from each quadrupole is scanned every 12 hours to ensure that the masses of the monitored MRM transitions remain within the expected 1 amu window (see Calibration Check, Section 10.1.4.).

Note: Excessive PFTBA (or any other reference substance) may cause elevated noise and also contamination of the ion source necessitating increased frequency of source cleaning.

10.1.2.2 Mass Tuning and Calibration. Prior to the analysis of any samples, including MS/MSDs, blanks, or calibration standards, the GC-MS/MS system must be tuned to meet the manufacturer's specification using a suitable calibrant, such as perfluorotributylamine (PFTBA). Refer to the instrument instruction manual for instructions on performing tuning and calibration for MS operation and then MS/MS to optimize the mass resolution and calibrate the mass scale. Verify that resolution and mass accuracy of m/z 69, 264, and 502 are within the manufacturer's specifications.

10.1.2.3 Calibration and Tuning check. At the beginning of each analytical sequence, verify that the mass resolution and mass accuracy still meet the criteria by analyzing a VER-CS3 standard. If the VER-CS3 does not pass the criteria in Table 6, then the instrument will need to be recalibrated, and any samples analyzed since the last successful check will need to be reanalyzed.

10.1.3 Multiple Reaction Monitoring (MRM). MRM analysis is required to achieve specificity in the CDD/CDF analysis. Quantitative analysis is performed in the MRM mode by monitoring at least two MRM transitions for each analyte and labeled standard. In all cases, two masses from the molecular ion cluster are used as the precursors while the product ion is due to loss of neutral [COCl] from the molecular ion. The two MRM transitions monitored for each analyte, standard, reference compound and potential interference are given in Table 8. The MRM transitions used for a given analyte must use identical conditions for the fragmentation reaction for both transitions for the analyte and for its labeled analog.

10.1.4 Stability of Detector Response and Influence of Other Compounds

10.1.4.1 Reference Compound. The intensity of the detector response may be impacted (suppressed or enhanced) by sample matrix in the detector at the same time as the analyte. To monitor for this type of interference, introduce a small amount of a reference compound, perfluorotributylamine (PFTBA), into the detector at a

constant rate throughout the run. The intensity of a single MRM transition of this reference compound is monitored in each MRM group of the analytical run. The level of PFTBA is introduced into the detector with a very short event time, so that response does not impact detector gain/voltage settings. Under these conditions, sensitivity changes due to interferences in the sample matrix can be more effectively monitored. This step (10.1.4.1) may be omitted if the requirements of Section 9 are met.

- 10.1.4.2** Chlorodiphenyl ethers may give a response in the MRM transitions monitored for the PCDFs. Therefore, MRM transitions specific to the chlorodiphenyl ether compounds, one per each MRM group, are monitored throughout the analytical run (see Table 8).
- 10.1.4.3** Some PCB congeners give a very small response in the MRM transitions monitored for PCDD/PCDF (similar or lower than with HRMS). If PCBs were not eliminated from the extract during the cleanup or, if very high concentrations of PCBs in the extract are possible, MRM transitions specific to the PCBs can be monitored to ensure that they do not interfere with the quantification of PCDD/PCDF. See Table 8 for details of PCB MRM transitions that could be monitored in each function if there is concern that significant concentrations of PCBs could be present.

10.2 MRM Transition product ion ratios, minimum levels, signal-to-noise ratios, and absolute retention times—Inject a 1 μ L aliquot of the CS1 calibration solution (Table 4) using the GC conditions from Section 10.1.1. If only 2,3,7,8-TCDD and 2,3,7,8-TCDF are to be determined, the operating conditions and specifications below apply to analysis of those compounds only.

10.2.1 Monitor at least two MRM transitions for each analyte and compute their product ion ratios for the MRM transitions specified in Table 8. Compare the computed ratio to the ratio given in Table 9. MRM transitions must be within the limits specified in Table 9, or the compound is flagged or marked as not detected.

10.2.1.1 The MRM transitions to be monitored in each function are shown in Table 8. Each group or function shall be monitored in succession as a function of GC retention time to ensure that all CDDs/CDFs are detected.

10.2.1.2 Additional MRM transitions may be monitored in each function, and the transitions may be divided among more than the five functions listed in Table 8, provided that the laboratory is able to monitor the MRM transitions of all the CDDs/CDFs that may elute from the GC in a given retention-time window. If only 2,3,7,8-TCDD and 2,3,7,8-TCDF are to be determined, the functions may be modified to include only the MRM transitions for the tetra- and penta-isomers, the chlorodiphenyl ethers and the reference compound (PFTBA) if used.

10.2.1.3 The response of the MRM transition shown in Table 8 for the reference compound (PFTBA) is monitored in each MRM group. The response of the PFTBA must not drift by more than $\pm 20\%$. Variations by more than 20% within the elution window of a CDD/CDF indicates the presence of coeluting interferences that may significantly alter the response of the mass spectrometer. Reinjection of another aliquot of the sample extract will not resolve the problem. Additional cleanup of the extract may be required to remove the interferences. This step may be omitted if the requirements of Section 9 Quality Assurance/Quality

Control are met.

- 10.2.2** All CDDs/CDFs and labeled compounds in the CS1 standard shall be within the QC limits in Table 9 for their respective MRM product ion ratios; otherwise, the mass spectrometer shall be adjusted and this test repeated until the ratios fall within the limits specified. If the adjustment alters the resolution of the mass spectrometer, resolution shall be verified (Section 10.1.2) prior to repeat of the test.
- 10.2.3** Verify that the GC-MS/MS instrument meets the minimum levels in Table 2. The peak area of the product ions of the MRMs for each CDDs/CDF and labeled compound in the CS1 calibration standard must have signal-to-noise ratios (S/N) greater than or equal to 10.0. Otherwise, the mass spectrometer shall be adjusted and this test repeated until the minimum levels in Table 2 are met.
- 10.2.4** The absolute retention time of $^{13}\text{C}_{12}$ -1,2,3,4-TCDD (Section 7.12) shall exceed 25.0 minutes on the DB-5 column, and the retention time of $^{13}\text{C}_{12}$ -1,2,3,4-TCDD shall exceed 15.0 minutes on the DB-225 column; otherwise, the GC temperature program shall be adjusted and this test repeated until the above-stated minimum retention time criteria are met.
- 10.3 Retention-time windows—Analyze the window defining mixtures (Section 7.15) using the optimized temperature program in Section 10.1. Table 5 gives the elution order (first/last) of the window-defining compounds. If 2,3,7,8-TCDD and 2,3,7,8-TCDF only are to be analyzed, this test is not required.
- 10.4 Isomer specificity
- 10.4.1** Analyze the isomer specificity test standards (Section 7.15) using the procedure in Section 14 and the optimized conditions for sample analysis (Section 10.1.1).
- 10.4.2** Compute the percent valley between the GC peaks that elute most closely to the 2,3,7,8-TCDD and TCDF isomers, on their respective columns, per Figures 6 and 7.
- 10.4.3** Verify that the height of the valley between the most closely eluted isomers and the 2,3,7,8-substituted isomers is less than 25% (computed as $100 \times y$ in Figures 6 and 7). If the valley exceeds 25%, adjust the analytical conditions and repeat the test or replace the GC column and recalibrate (Sections 10.1.2 through 10.7).
- 10.5 Calibration by isotope dilution—Isotope dilution calibration is used for the fifteen 2,3,7,8-substituted CDDs/CDFs for which labeled compounds are added to samples prior to extraction. The reference compound for each CDD/CDF compound is shown in Table 2.
- 10.5.1** A calibration curve encompassing the concentration range is prepared for each compound to be determined. The relative response (RR) (labeled to native) vs. concentration in standard solutions is plotted or computed using a linear regression. Relative response is determined according to the procedures described below. Five calibration points are employed.
- 10.5.2** The response of each CDD/CDF relative to its labeled analog is determined using the area responses of the primary product ions for the MRMs specified in Table 8, for each calibration standard, as follows:

$$RR = \frac{A_n C_l}{A_l C_n}$$

where:

A_n = The area of the primary quantification ion for the CDD/CDF.

A_l = The areas of the primary quantification ion for the labeled compound.

C_l = The concentration of the labeled compound in the calibration standard (Table 4).

C_n = The concentration of the native compound in the calibration standard (Table 4).

10.5.3 To calibrate the analytical system by isotope dilution, inject a volume of calibration standards CS1 through CS5 (Section 7.13 and Table 4) identical to the volume chosen in Section 10.2, using the procedure in Section 14 and the conditions in Section 10.1.1 and Table 2. Compute the relative response (RR) at each concentration.

10.5.4 Linearity—If the relative response for any compound is constant (less than 20% coefficient of variation) over the five-point calibration range, an averaged relative response may be used for that compound; otherwise, the complete calibration curve for that compound shall be used over the five-point calibration range.

10.6 Calibration by internal standard—The internal standard method is applied to determination of 1,2,3,7,8,9-HxCDD (Section 17.1.2), OCDF (Section 17.1.1), the non-2,3,7,8-substituted compounds, and to the determination of labeled compounds for intralaboratory statistics (Sections 9.4 and 15.5.4).

10.6.1 Response factors—Calibration requires the determination of response factors (RF) defined by the following equation:

$$RF = \frac{A_s C_{IS}}{A_{IS} C_s}$$

where:

A_s = The measured area of the quantification ion for the CDD/CDF.

A_{IS} = The measured area of the quantification ion for the IS.

C_{IS} = The concentration of the IS in the calibration standard (Table 4).

C_s = The concentration of the compound in the calibration standard (Table 4).

Note: There is no confirmation ion criteria for $^{37}\text{Cl}_4$ -2,3,7,8-TCDD. See Table 9.

10.6.2 To calibrate the analytical system by internal standard, inject 1.0 μL of calibration standards CS1 through CS5 (Section 7.13 and Table 4) using the procedure in Section 14 and the conditions in Section 10.1.1 and Table 2. Compute the response factor (RF) at each concentration.

10.6.3 Linearity—If the response factor (RF) for any compound is constant (less than 35% coefficient of variation) over the five-point calibration range, an averaged response factor may be used for that compound; otherwise, the complete calibration curve for that compound shall be used over the five-point range.

10.7 Combined calibration—By using calibration solutions (Section 7.13 and Table 4) containing the CDDs/CDFs and labeled compounds and the internal standards, a single set of analyses can be used

to produce calibration curves for the isotope dilution and internal standard methods. These curves are verified each shift (Section 15.3) by analyzing the calibration verification standard (VER, Table 4). Recalibration is required if any of the calibration verification criteria (Section 15.3) cannot be met.

10.8 Data storage—MS/MS data shall be collected, recorded, and stored.

10.8.1 Data acquisition—Collect the signal for each MRM throughout the monitoring period and store on a secure hard drive containing the data processing software.

10.8.2 Response factors and multipoint calibrations—The data system records and maintains lists of response factors (response ratios for isotope dilution) and multipoint calibration curves. Computations of relative standard deviation are used to verify calibration linearity. Statistics on initial performance (Section 9.2) and ongoing performance (Section 15.5) are computed and maintained, either on the instrument data system, or on a separate secure data system.

11.0 Sample Preparation

11.1 Sample preparation involves modifying the physical form of the sample so that the CDDs/CDFs can be extracted efficiently. In general, the samples must be in a liquid form or in the form of finely divided solids in order for efficient extraction to take place. Table 10 lists the phases and suggested quantities for extraction of various sample matrices.

For samples known or expected to contain high levels of the CDDs/CDFs, the smallest sample size representative of the entire sample should be used (see Section 17.5).

For all samples, the blank and IPR/OPR aliquots must be processed through the same steps as the sample to check for contamination and losses in the preparation processes.

11.1.1 For samples that contain particles, percent solids and particle size are determined using the procedures in Sections 11.2 and 11.3, respectively.

11.1.2 Aqueous samples—Because CDDs/CDFs may be bound to suspended particles, the preparation of aqueous samples is dependent on the solids content of the sample.

11.1.2.1 Aqueous samples visibly absent particles are prepared per Section 11.4 and extracted directly using the separatory funnel or SPE techniques in Sections 12.1 or 12.2, respectively.

11.1.2.2 Aqueous samples containing visible particles and containing one percent suspended solids or less are prepared using the procedure in Section 11.4. After preparation, the sample is extracted directly using the SPE technique in 12.2 or filtered per Section 11.4.3. After filtration, the particles and filter are extracted using the SDS procedure in Section 12.3 and the filtrate is extracted using the separatory funnel procedure in Section 12.1.

11.1.2.3 For aqueous samples containing greater than one percent solids, a sample aliquot sufficient to provide 10 g of dry solids is used, as described in Section 11.5.

11.1.3 Solid samples are prepared using the procedure described in Section 11.5 followed by extraction via the SDS procedure in Section 12.3.

11.1.4 Multiphase samples—The phase(s) containing the CDDs/CDFs is separated from the non-CDD/CDF phase using pressure filtration and centrifugation, as described in Section 11.6.

The CDDs/CDFs will be in the organic phase in a multiphase sample in which an organic phase exists.

11.1.5 Procedures for grinding, homogenization, and blending of various sample phases are given in Section 11.7.

11.1.6 Tissue samples—Preparation procedures for fish and other tissues are given in Section 11.8.

11.2 Determination of percent suspended solids.

Note: This aliquot is used for determining the solids content of the sample, not for determination of CDDs/CDFs.

11.2.1 Aqueous liquids and multi-phase samples consisting of mainly an aqueous phase.

11.2.1.1 Desiccate and weigh a GF/D filter (Section 6.5.3) to three significant figures.

11.2.1.2 Filter 10.0 ± 0.02 mL of well-mixed sample through the filter.

11.2.1.3 Dry the filter a minimum of 12 hours at 110 ± 5 °C and cool in a desiccator.

11.2.1.4 Calculate percent solids as follows:

$$\% \text{ solids} = \frac{\text{weight of sample aliquot after drying (g)} - \text{weight of filter (g)}}{10 \text{ g}} \times 100$$

11.2.2 Non-aqueous liquids, solids, semi-solid samples, and multi-phase samples in which the main phase is not aqueous; but not tissues.

11.2.2.1 Weigh 5 to 10 g of sample to three significant figures in a tared beaker.

11.2.2.2 Dry a minimum of 12 hours at 110 ± 5 °C, and cool in a desiccator.

11.2.2.3 Calculate percent solids as follows:

$$\% \text{ solids} = \frac{\text{weight of sample aliquot after drying}}{\text{weight of sample aliquote before drying}} \times 100$$

11.3 Determination of particle size.

11.3.1 Spread the dried sample from Section 11.2.2.2 on a piece of filter paper or aluminum foil in a fume hood or glove box.

11.3.2 Estimate the size of the particles in the sample. If the size of the largest particles is greater than 1 mm, the particle size must be reduced to 1 mm or less prior to extraction using the procedures in Section 11.7.

11.4 Preparation of aqueous samples containing one percent suspended solids or less.

11.4.1 Aqueous samples visibly absent particles are prepared per the procedure below and extracted directly using the separatory funnel or SPE techniques in Sections 12.1 or 12.2, respectively.

Aqueous samples containing visible particles and one percent suspended solids or less are prepared using the procedure below and extracted using either the SPE technique in Section 12.2 or further prepared using the filtration procedure in Section 11.4.3. The filtration procedure is followed by SDS extraction of the filter and particles (Section 12.3) and separatory funnel extraction of the filtrate (Section 12.1). The SPE procedure is followed by SDS extraction of the filter and disk.

11.4.2 Preparation of sample and QC aliquots.

- 11.4.2.1** Mark the original level of the sample on the sample bottle for reference. Weigh the sample plus bottle to ± 1 g.
- 11.4.2.2** Spike 1.0 mL of the diluted labeled-compound spiking solution (Section 7.10.3) into the sample bottle. Cap the bottle and mix the sample by careful shaking. Allow the sample to equilibrate for 1 to 2 hours, with occasional shaking.
- 11.4.2.3** For each sample or sample batch (to a maximum of 20 samples) to be extracted during the same 12-hour shift, place two 1.0-L aliquots of reagent water in clean sample bottles or flasks.
- 11.4.2.4** Spike 1.0 mL of the diluted labeled-compound spiking solution (Section 7.10.3) into both reagent water aliquots. One of these aliquots will serve as the method blank.
- 11.4.2.5** Spike 1.0 mL of the PAR standard (Section 7.14) into the remaining reagent water aliquot. This aliquot will serve as the OPR (Section 15.5).
- 11.4.2.6** If SPE is to be used, add 5 mL of methanol to the sample, cap and shake the sample to mix thoroughly, and proceed to Section 12.2 for extraction. If SPE is not to be used, and the sample is visibly absent particles, proceed to Section 12.1 for extraction. If SPE is not to be used and the sample contains visible particles, proceed to the following section for filtration of particles.

11.4.3 Filtration of particles.

- 11.4.3.1** Assemble a Buchner funnel (Section 6.5.5) on top of a clean filtration flask. Apply vacuum to the flask, and pour the entire contents of the sample bottle through a glass-fiber filter (Section 6.5.6) in the Buchner funnel, swirling the sample remaining in the bottle to suspend any particles.
- 11.4.3.2** Rinse the sample bottle twice with approximately 5-mL portions of reagent water to transfer any remaining particles onto the filter.
- 11.4.3.3** Rinse any particles off the sides of the Buchner funnel with small quantities of reagent water.
- 11.4.3.4** Weigh the empty sample bottle to ± 1 g. Determine the weight of the sample by difference. Save the bottle for further use.
- 11.4.3.5** Extract the filtrate using the separatory funnel procedure in Section 12.1.
- 11.4.3.6** Extract the filter containing the particles using the SDS procedure in Section 12.3.

11.5 Preparation of samples containing greater than one percent solids.

- 11.5.1** Weigh a well-mixed aliquot of each sample (of the same matrix type) sufficient to provide 10 g of dry solids (based on the solids determination in Section 11.2) into a clean beaker or glass jar.
 - 11.5.2** Spike 1.0 mL of the diluted labeled compound spiking solution (Section 7.10.3) into the sample.
 - 11.5.3** For each sample or sample batch (to a maximum of 20 samples) to be extracted during the same 12-hour shift, weigh two 10-g aliquots of the appropriate reference matrix (Section 7.6) into clean beakers or glass jars.
 - 11.5.4** Spike 1.0 mL of the diluted labeled compound spiking solution (Section 7.10.3) into each reference matrix aliquot. One aliquot will serve as the method blank. Spike 1.0 mL of the PAR standard (Section 7.14) into the other reference matrix aliquot. This aliquot will serve as the OPR (Section 15.5).
 - 11.5.5** Stir or tumble and equilibrate the aliquots for 1 to 2 hours.
 - 11.5.6** Decant excess water. If necessary to remove water, filter the sample through a glass-fiber filter and discard the aqueous liquid.
 - 11.5.7** If particles >1 mm are present in the sample (as determined in Section 11.3.2), spread the sample on clean aluminum foil in a hood. After the sample is dry, grind to reduce the particle size (Section 11.7).
 - 11.5.8** Extract the sample and QC aliquots using the SDS procedure in Section 12.3.
- 11.6 Multiphase samples.
- 11.6.1** Using the percent solids determined in Section 11.2.1 or 11.2.2, determine the volume of sample that will provide 10 g of solids, up to 1 L of sample.
 - 11.6.2** Pressure filter the amount of sample determined in Section 11.6.1 through Whatman GF/D glass-fiber filter paper (Section 6.5.3). Pressure filter the blank and OPR aliquots through GF/D papers also. If necessary to separate the phases and/or settle the solids, centrifuge these aliquots prior to filtration.
 - 11.6.3** Discard any aqueous phase (if present). Remove any non-aqueous liquid present and reserve the maximum amount filtered from the sample (Section 11.6.1) or 10 g, whichever is less, for combination with the solid phase (Section 12.3.5).
 - 11.6.4** If particles >1 mm are present in the sample (as determined in Section 11.3.2) and the sample is capable of being dried, spread the sample and QC aliquots on clean aluminum foil in a hood. After the aliquots are dry or if the sample cannot be dried, reduce the particle size using the procedures in Section 11.7 and extract the reduced particles using the SDS procedure in Section 12.3. If particles >1 mm are not present, extract the particles and filter in the sample and QC aliquots directly using the SDS procedure in Section 12.3.
- 11.7 Sample grinding, homogenization, or blending—Samples with particle sizes greater than 1 mm (as determined in Section 11.3.2) are subjected to grinding, homogenization, or blending. The method of reducing particle size to less than 1 mm is matrix-dependent. In general, hard particles can be reduced by grinding with a mortar and pestle. Softer particles can be reduced by grinding in a Wiley mill or meat grinder, by homogenization, or in a blender.
- 11.7.1** Each size-reducing preparation procedure on each matrix shall be verified by running the tests

in Section 9.2 before the procedure is employed routinely.

- 11.7.2** The grinding, homogenization, or blending procedures shall be carried out in a glove box or fume hood to prevent particles from contaminating the work environment.
 - 11.7.3** Grinding—Certain papers and pulps, slurries, and amorphous solids can be ground in a Wiley mill or heavy-duty meat grinder. In some cases, reducing the temperature of the sample to freezing or to dry ice or liquid nitrogen temperatures can aid in the grinding process. Grind the sample aliquots from Sections 11.5.7 or 11.6.4 in a clean grinder. Do not allow the sample temperature to exceed 50 °C. Grind the blank and reference matrix aliquot using a clean grinder.
 - 11.7.4** Homogenization or blending—Particles that are not ground effectively, or particles greater than 1 mm in size after grinding, can often be reduced in size by high-speed homogenization or blending. Homogenize and/or blend the particles or filter from Sections 11.5.7 or 11.6.4 for the sample, blank, and OPR aliquots.
 - 11.7.5** Extract the aliquots using the SDS procedure in Section 12.3.
- 11.8 Fish and other tissues—Prior to processing tissue samples, the laboratory must determine the exact tissue to be analyzed. Common requests for analysis of fish tissue include whole fish—skin on, whole fish—skin removed, edible fish fillets (filleted in the field or by the laboratory), specific organs, and other portions. Once the appropriate tissue has been determined, the sample must be homogenized.
- 11.8.1** Homogenization.
 - 11.8.1.1** Samples are homogenized while still frozen, where practical. If the laboratory must dissect the whole fish to obtain the appropriate tissue for analysis, the unused tissues may be rapidly refrozen and stored in a clean glass jar for subsequent use.
 - 11.8.1.2** Each analysis requires 10 g of tissue (wet weight). Therefore, the laboratory should homogenize at least 20 g of tissue to allow for re-extraction of a second aliquot of the same homogenized sample, if re-analysis is required. When whole fish analysis is necessary, the entire fish is homogenized.
 - 11.8.1.3** Homogenize the sample in a tissue homogenizer (Section 6.3.3) or grind in a meat grinder (Section 6.3.4). Cut tissue too large to feed into the grinder into smaller pieces. To assure homogeneity, grind three times.
 - 11.8.1.4** Transfer approximately 10 g (wet weight) of homogenized tissue to a clean, tared, 400- to 500-mL beaker. For the alternate HCl digestion/extraction, transfer the tissue to a clean, tared 500- to 600-mL wide-mouth bottle. Record the weight to the nearest 10 mg.
 - 11.8.1.5** Transfer the remaining homogenized tissue to a clean jar with a fluoropolymer-lined lid. Seal the jar and store the tissue at <-10 °C. Return any tissue that was not homogenized to its original container and store at <-10 °C.
 - 11.8.2** QC aliquots.
 - 11.8.2.1** Prepare a method blank by adding approximately 10 g of the oily liquid reference matrix (Section 7.6.4) to a 400- to 500-mL beaker. For the alternate HCl digestion/extraction, add the reference matrix to a 500- to 600-mL wide-mouth bottle. Record the weight to the nearest 10 mg.

11.8.2.2 Prepare a precision and recovery aliquot by adding approximately 10 g of the oily liquid reference matrix (Section 7.6.4) to a separate 400- to 500-mL beaker or wide-mouth bottle, depending on the extraction procedure to be used. Record the weight to the nearest 10 mg. If the initial precision and recovery test is to be performed, use four aliquots; if the ongoing precision and recovery test is to be performed, use a single aliquot.

11.8.3 Spiking.

11.8.3.1 Spike 1.0 mL of the labeled compound spiking solution (Section 7.10.3) into the sample, blank, and OPR aliquot.

11.8.3.2 Spike 1.0 mL of the PAR standard (Section 7.14) into the OPR aliquot.

11.8.4 Extract the aliquots using the procedures in Section 12.4.

12.0 Extraction and Concentration

Extraction procedures include separatory funnel (Section 12.1) and solid phase (Section 12.2) for aqueous liquids; Soxhlet/Dean-Stark (Section 12.3) for solids, filters, and SPE disks; and Soxhlet extraction (Section 12.4.1) and HCl digestion (Section 12.4.2) for tissues. Acid/base back-extraction (Section 12.5) is used for initial cleanup of extracts.

Macro-concentration procedures include rotary evaporation (Section 12.6.1), heating mantle (Section 12.6.2), and Kuderna-Danish (K-D) evaporation (Section 12.6.3). Micro-concentration uses nitrogen blowdown (Section 12.7).

12.1 Separatory funnel extraction of filtrates and of aqueous samples visibly absent particles.

12.1.1 Pour the spiked sample (Section 11.4.2.2) or filtrate (Section 11.4.3.5) into a 2-L separatory funnel. Rinse the bottle or flask twice with 5 mL of reagent water and add these rinses to the separatory funnel.

12.1.2 Add 60 mL methylene chloride to the empty sample bottle (Section 12.1.1), seal, and shake 60 seconds to rinse the inner surface. Transfer the solvent to the separatory funnel, and extract the sample by shaking the funnel for 2 minutes with periodic venting. Allow the organic layer to separate from the aqueous phase for a minimum of 10 minutes. If an emulsion forms and is more than one-third the volume of the solvent layer, employ mechanical techniques to complete the phase separation (see note below). Drain the methylene chloride extract through a solvent-rinsed glass funnel approximately one-half full of granular anhydrous sodium sulfate (Section 7.2.1) supported on clean glass-fiber paper into a solvent-rinsed concentration device (Section 12.6).

Note: If an emulsion forms, the analyst must employ mechanical techniques to complete the phase separation. The optimum technique depends upon the sample, but may include stirring, filtration through glass wool, use of phase separation paper, centrifugation, use of an ultrasonic bath with ice, addition of NaCl, or other physical methods. Alternatively, solid-phase or other extraction techniques may be used to prevent emulsion formation. Any alternative technique is acceptable so long as the requirements in Section 9 Quality Assurance/Quality Control are met.

Experience with aqueous samples high in dissolved organic materials (e.g., paper mill effluents) has shown that acidification of the sample prior to extraction may reduce the formation of emulsions. Paper industry methods suggest that the addition of up to 400 mL of ethanol to a 1-L effluent sample may also reduce emulsion formation. However, studies by EPA suggest that the effect may be a result of sample dilution, and that the addition of reagent water may serve the same function. Mechanical techniques may still be necessary to complete the phase separation. If either acidification or addition of ethanol is utilized, the laboratory must perform the startup tests described in Section 9.2 using the same techniques.

12.1.3 Extract the water sample two more times with 60-mL portions of methylene chloride. Drain each portion through the sodium sulfate into the concentrator. After the third extraction, rinse the separatory funnel with at least 20 mL of methylene chloride, and drain this rinse through the sodium sulfate into the concentrator. Repeat this rinse at least twice. Set aside the funnel with sodium sulfate if the extract is to be combined with the extract from the particles.

12.1.4 Concentrate the extract using one of the macro-concentration procedures in Section 12.6.

12.1.4.1 If the extract is from a sample visibly absent particles (Section 11.1.2.1), adjust the final volume of the concentrated extract to approximately 10 mL with hexane, transfer to a 250-mL separatory funnel, and back-extract using the procedure in Section 12.5.

12.1.4.2 If the extract is from the aqueous filtrate (Section 11.4.3.5), set aside the concentration apparatus for addition of the SDS extract from the particles (Section 12.3.9.1.2).

12.2 SPE of samples containing less than one percent solids. (References 19-20).

12.2.1 Disk preparation.

12.2.1.1 Place an SPE disk on the base of the filter holder (Figure 4) and wet with toluene. While holding a GMF 150 filter above the SPE disk with tweezers, wet the filter with toluene and lay the filter on the SPE disk, making sure that air is not trapped between the filter and disk. Clamp the filter and SPE disk between the 1-L glass reservoir and the vacuum filtration flask.

12.2.1.2 Rinse the sides of the filtration flask with approx. 15 mL of toluene using a squeeze bottle or syringe. Apply vacuum momentarily until a few drops appear at the drip tip. Release the vacuum and allow the filter/disk to soak for approx. one minute. Apply vacuum and draw all of the toluene through the filter/disk. Repeat the wash step with approx. 15 mL of acetone and allow the filter/disk to air dry.

12.2.1.3 Re-wet the filter/disk with approximately 15 mL of methanol, allowing the filter/disk to soak for approximately 1 minute. Pull the methanol through the filter/disk using the vacuum, but retain a layer of methanol approximately 1 mm thick on the filter. Do not allow the disk to go dry from this point until the end of the extraction.

12.2.1.4 Rinse the filter/disk with two 50-mL portions of reagent water by adding the water to the reservoir and pulling most through, leaving a layer of water on the surface of the filter.

12.2.2 Extraction.

- 12.2.2.1** Pour the spiked sample (Section 11.4.2.2), blank (Section 11.4.2.4), or IPR/OPR aliquot (Section 11.4.2.5) into the reservoir and turn on the vacuum to begin the extraction. Adjust the vacuum to complete the extraction in no less than 10 minutes. For samples containing a high concentration of particles (suspended solids), filtration times may be 8 hours or longer.
- 12.2.2.2** Before all of the sample has been pulled through the filter/disk, rinse the sample bottle with approximately 50 mL of reagent water to remove any solids, and pour into the reservoir. Pull through the filter/disk. Use additional reagent water rinses until all visible solids are removed.
- 12.2.2.3** Before all of the sample and rinses have been pulled through the filter/disk, rinse the sides of the reservoir with small portions of reagent water.
- 12.2.2.4** Allow the filter/disk to dry, then remove the filter and disk and place in a glass petri dish. Extract the filter and disk per Section 12.3.

12.3 SDS extraction of samples containing particles, and of filters and/or disks.

- 12.3.1** Charge a clean extraction thimble (Section 6.4.2.2) with 5.0 g of 100/200 mesh silica (Section 7.5.1.1) topped with 100 g of quartz sand (Section 7.3.2).

Note: Do not disturb the silica layer throughout the extraction process.

- 12.3.2** Place the thimble in a clean extractor. Place 30 to 40 mL of toluene in the receiver and 200 to 250 mL of toluene in the flask.
- 12.3.3** Pre-extract the glassware by heating the flask until the toluene is boiling. When properly adjusted, 1 to 2 drops of toluene will fall per second from the condenser tip into the receiver. Extract the apparatus for a minimum of 3 hours.
- 12.3.4** After pre-extraction, cool and disassemble the apparatus. Rinse the thimble with toluene and allow to air dry.
- 12.3.5** Load the wet sample, filter, and/or disk from Sections 11.4.3.6, 11.5.8, 11.6.4, 11.7.3, 11.7.4, or 12.2.2.4 and any nonaqueous liquid from Section 11.6.3 into the thimble and manually mix into the sand layer with a clean metal spatula, carefully breaking up any large lumps of sample.
- 12.3.6** Reassemble the pre-extracted SDS apparatus, and add a fresh charge of toluene to the receiver and reflux flask. Apply power to the heating mantle to begin refluxing. Adjust the reflux rate to match the rate of percolation through the sand and silica beds until water removal lessens the restriction to toluene flow. Frequently check the apparatus for foaming during the first 2 hours of extraction. If foaming occurs, reduce the reflux rate until foaming subsides.
- 12.3.7** Drain the water from the receiver at 1 to 2 hours and 8 to 9 hours, or sooner if the receiver fills with water. Reflux the sample for a total of 16 to 24 hours. Cool and disassemble the apparatus. Record the total volume of water collected.
- 12.3.8** Remove the distilling flask. Drain the water from the Dean-Stark receiver and add any toluene in the receiver to the extract in the flask.
- 12.3.9** Concentrate the extract using one of the macro-concentration procedures in Section 12.6 per the following:

12.3.9.1 Extracts from the particles in an aqueous sample containing less than one percent solids (Section 11.4.3.6).

12.3.9.1.1 Concentrate the extract to approximately 5 mL using the rotary evaporator or heating mantle procedures in Sections 12.6.1 or 12.6.2.

12.3.9.1.2 Quantitatively transfer the extract through the sodium sulfate (Section 12.1.3) into the apparatus that was set aside (Section 12.1.4.2) and reconcentrate to the level of the toluene.

12.3.9.1.3 Adjust to approximately 10 mL with hexane, transfer to a 250-mL separatory funnel, and proceed with back-extraction (Section 12.5).

12.3.9.2 Extracts from particles (Sections 11.5-11.6) or from the SPE filter and disk (Section 12.2.2.4)—Concentrate to approximately 10 mL using the rotary evaporator or heating mantle (Section 12.6.1 or 12.6.2), transfer to a 250-mL separatory funnel, and proceed with back-extraction (Section 12.5).

12.4 Extraction of tissue—Two procedures are provided for tissue extraction.

12.4.1 Soxhlet extraction (Reference 21).

12.4.1.1 Add 30 to 40 g of powdered anhydrous sodium sulfate to each of the beakers (Section 11.8.4) and mix thoroughly. Cover the beakers with aluminum foil and allow to equilibrate for 12-24 hours. Remix prior to extraction to prevent clumping.

12.4.1.2 Assemble and pre-extract the Soxhlet apparatus per Sections 12.3.1-12.3.4, except use the methylene chloride:hexane (1:1) mixture for the pre-extraction and rinsing and omit the quartz sand. The Dean-Stark moisture trap may also be omitted, if desired.

12.4.1.3 Reassemble the pre-extracted Soxhlet apparatus and add a fresh charge of methylene chloride:hexane to the reflux flask.

12.4.1.4 Transfer the sample/sodium sulfate mixture (Section 12.4.1.1) to the Soxhlet thimble, and install the thimble in the Soxhlet apparatus.

12.4.1.5 Rinse the beaker with several portions of solvent mixture and add to the thimble. Fill the thimble/receiver with solvent. Extract for 18 to 24 hours.

12.4.1.6 After extraction, cool and disassemble the apparatus.

12.4.1.7 Quantitatively transfer the extract to a macro-concentration device (Section 12.6), and concentrate to near dryness. Set aside the concentration apparatus for re-use.

12.4.1.8 Complete the removal of the solvent using the nitrogen blowdown procedure (Section 12.7) and a water bath temperature of 60 °C. Weigh the receiver, record the weight, and return the receiver to the blowdown apparatus, concentrating the residue until a constant weight is obtained.

12.4.1.9 Percent lipid determination—The lipid content is determined by extraction of tissue with the same solvent system (methylene chloride:hexane) that was used in EPA's National Dioxin Study (Reference 22) so that lipid contents are consistent with that study.

12.4.1.9.1 Redissolve the residue in the receiver in hexane and spike 1.0 mL of the cleanup standard (Section 7.11) into the solution.

12.4.1.9.2 Transfer the residue/hexane to the anthropogenic isolation column (Section 13.7.1) or bottle for the acidified silica gel batch cleanup (Section 13.7.2), retaining the boiling chips in the concentration apparatus. Use several rinses to assure that all material is transferred. If necessary, sonicate or heat the receiver slightly to assure that all material is redissolved. Allow the receiver to dry. Weigh the receiver and boiling chips.

12.4.1.9.3 Calculate the lipid content to the nearest three significant figures as follows:

$$\text{Percent lipid} = \frac{\text{Weight of residue (g)}}{\text{Weight of tissue (g)}} \times 100$$

12.4.1.9.4 It is not necessary to determine the lipid content of the blank, IPR, or OPR aliquots.

12.4.2 HCl digestion/extraction and concentration (References 23-26).

12.4.2.1 Add 200 mL of 6 N HCl and 200 mL of methylene chloride:hexane (1:1) to the sample and QC aliquots (Section 11.8.4).

12.4.2.2 Cap and shake each bottle 1 to 3 times. Loosen the cap in a hood to vent excess pressure. Shake each bottle for 10 to 30 seconds and vent.

12.4.2.3 Tightly cap and place on shaker. Adjust the shaker action and speed so that the acid, solvent, and tissue are in constant motion. However, take care to avoid such violent action that the bottle may be dislodged from the shaker. Shake for 12 to 24 hours.

12.4.2.4 After digestion, remove the bottles from the shaker. Allow the bottles to stand so that the solvent and acid layers separate.

12.4.2.5 Decant the solvent through a glass funnel with glass-fiber filter (Sections 6.5.2-6.5.3) containing approximately 10 grams of granular anhydrous sodium sulfate (Section 7.2.1) into a macro-concentration apparatus (Section 12.6). Rinse the contents of the bottle with two 25-mL portions of hexane and pour through the sodium sulfate into the apparatus.

12.4.2.6 Concentrate the solvent to near dryness using a macro-concentration procedure (Section 12.6).

12.4.2.7 Complete the removal of the solvent using the nitrogen blowdown apparatus (Section 12.7) and a water bath temperature of 60 °C. Weigh the receiver, record the weight, and return the receiver to the blowdown apparatus, concentrating the residue until a constant weight is obtained.

12.4.2.8 Percent lipid determination—The lipid content is determined in the same solvent system [methylene chloride:hexane (1:1)] that was used in EPA's National Dioxin Study (Reference 22) so that lipid contents are consistent with that study.

12.4.2.8.1 Redissolve the residue in the receiver in hexane and spike 1.0 mL of the cleanup standard (Section 7.11) into the solution.

12.4.2.8.2 Transfer the residue/hexane to the narrow-mouth 100- to 200-mL bottle retaining the boiling chips in the receiver. Use several rinses to assure that all material is transferred, to a maximum hexane volume of approximately 70 mL. Allow the receiver to dry. Weigh the receiver and boiling chips.

12.4.2.8.3 Calculate the percent lipid per Section 12.4.1.9.3. It is not necessary to determine the lipid content of the blank, IPR, or OPR aliquots.

12.4.2.9 Clean up the extract per Section 13.7.3.

12.5 Back-extraction with base and acid.

12.5.1 Spike 1.0 mL of the cleanup standard (Section 7.11) into the separatory funnels containing the sample and QC extracts from Section 12.1.4.1, 12.3.9.1.3, or 12.3.9.2.

12.5.2 Partition the extract against 50 mL of potassium hydroxide solution (Section 7.1.1). Shake for 2 minutes with periodic venting into a hood. Remove and discard the aqueous layer. Repeat the base washing until no color is visible in the aqueous layer, to a maximum of four washings. Minimize contact time between the extract and the base to prevent degradation of the CDDs/CDFs. Stronger potassium hydroxide solutions may be employed for back-extraction, provided that the laboratory meets the specifications for labeled compound recovery and demonstrates acceptable performance using the procedure in Section 9.2.

12.5.3 Partition the extract against 50 mL of sodium chloride solution (Section 7.1.4) in the same way as with base. Discard the aqueous layer.

12.5.4 Partition the extract against 50 mL of sulfuric acid (Section 7.1.2) in the same way as with base. Repeat the acid washing until no color is visible in the aqueous layer, to a maximum of four washings.

12.5.5 Repeat the partitioning against sodium chloride solution and discard the aqueous layer.

12.5.6 Pour each extract through a drying column containing 7 to 10 cm of granular anhydrous sodium sulfate (Section 7.2.1). Rinse the separatory funnel with 30 to 50 mL of solvent, and pour through the drying column. Collect each extract in a round-bottom flask. Re-concentrate the sample and QC aliquots per Sections 12.6-12.7, and clean up the samples and QC aliquots per Section 13.

12.6 Macro-concentration—Extracts in toluene are concentrated using a rotary evaporator or a heating mantle; extracts in methylene chloride or hexane are concentrated using a rotary evaporator, heating mantle, or Kuderna-Danish apparatus.

12.6.1 Rotary evaporation—Concentrate the extracts in separate round-bottom flasks.

12.6.1.1 Assemble the rotary evaporator according to manufacturer's instructions, and warm the water bath to 45 °C. On a daily basis, preclean the rotary evaporator by concentrating 100 mL of clean extraction solvent through the system. Archive both the concentrated solvent and the solvent in the catch flask for a contamination check if necessary. Between samples, three 2- to 3-mL aliquots of solvent should be rinsed down the feed tube into a waste beaker.

12.6.1.2 Attach the round-bottom flask containing the sample extract to the rotary evaporator. Slowly apply vacuum to the system and begin rotating the sample flask.

12.6.1.3 Lower the flask into the water bath and adjust the speed of rotation and the temperature as required to complete concentration in 15 to 20 minutes. At the proper rate of concentration, the flow of solvent into the receiving flask will be steady, but no bumping or visible boiling of the extract will occur.

Note: If the rate of concentration is too fast, analyte loss may occur.

- 12.6.1.4** When the liquid in the concentration flask has reached an apparent volume of approximately 2 mL, remove the flask from the water bath and stop the rotation. Slowly and carefully admit air into the system. Be sure not to open the valve so quickly that the sample is blown out of the flask. Rinse the feed tube with approximately 2 mL of solvent.
- 12.6.1.5** Proceed to Section 12.6.4 for preparation for back-extraction or micro-concentration and solvent exchange.
- 12.6.2** Heating mantle—Concentrate the extracts in separate round-bottom flasks.
- 12.6.2.1** Add one or two clean boiling chips to the round-bottom flask and attach a three-ball macro Snyder column. Prewet the column by adding approximately 1 mL of solvent through the top. Place the round-bottom flask in a heating mantle and apply heat as required to complete the concentration in 15 to 20 minutes. At the proper rate of distillation, the balls of the column will actively chatter, but the chambers will not flood.
- 12.6.2.2** When the liquid has reached an apparent volume of approximately 10 mL, remove the round-bottom flask from the heating mantle and allow the solvent to drain and cool for at least 10 minutes. Remove the Snyder column and rinse the glass joint into the receiver with small portions of solvent.
- 12.6.2.3** Proceed to Section 12.6.4 for preparation for back-extraction or micro-concentration and solvent exchange.
- 12.6.3** Kuderna-Danish (K-D)—Concentrate the extracts in separate 500-mL K-D flasks equipped with 10-mL concentrator tubes. The K-D technique is used for solvents such as methylene chloride and hexane. Toluene is difficult to concentrate using the K-D technique unless a water bath fed by a steam generator is used.
- 12.6.3.1** Add 1 to 2 clean boiling chips to the receiver. Attach a three-ball macro Snyder column. Prewet the column by adding approximately 1 mL of solvent through the top. Place the K-D apparatus in a hot water bath so that the entire lower rounded surface of the flask is bathed with steam.
- 12.6.3.2** Adjust the vertical position of the apparatus and the water temperature as required to complete the concentration in 15 to 20 minutes. At the proper rate of distillation, the balls of the column will actively chatter but the chambers will not flood.
- 12.6.3.3** When the liquid has reached an apparent volume of 1 mL, remove the K-D apparatus from the bath and allow the solvent to drain and cool for at least 10 minutes. Remove the Snyder column and rinse the flask and its lower joint into the concentrator tube with 1 to 2 mL of solvent. A 5-mL syringe is recommended for this operation.
- 12.6.3.4** Remove the three-ball Snyder column, add a fresh boiling chip, and attach a two-ball micro Snyder column to the concentrator tube. Prewet the column by adding approximately 0.5 mL of solvent through the top. Place the apparatus in the hot water bath.

- 12.6.3.5** Adjust the vertical position and the water temperature as required to complete the concentration in 5 to 10 minutes. At the proper rate of distillation, the balls of the column will actively chatter but the chambers will not flood.
- 12.6.3.6** When the liquid reaches an apparent volume of 0.5 mL, remove the apparatus from the water bath and allow to drain and cool for at least 10 minutes.
- 12.6.3.7** Proceed to 12.6.4 for preparation for back-extraction or micro-concentration and solvent exchange.
- 12.6.4** Preparation for back-extraction or micro-concentration and solvent exchange.
 - 12.6.4.1** For back-extraction (Section 12.5), transfer the extract to a 250-mL separatory funnel. Rinse the concentration vessel with small portions of hexane, adjust the hexane volume in the separatory funnel to 10 to 20 mL, and proceed to back-extraction (Section 12.5).
 - 12.6.4.2** For determination of the weight of residue in the extract, or for clean-up procedures other than back-extraction, transfer the extract to a blowdown vial using 2-3 rinses of solvent. Proceed with micro-concentration and solvent exchange (Section 12.7).

12.7 Micro-concentration and solvent exchange.

- 12.7.1** Extracts to be subjected to GPC or HPLC cleanup are exchanged into methylene chloride. Extracts to be cleaned up using silica gel, alumina, carbon, and/or Florisil are exchanged into hexane.
- 12.7.2** Transfer the vial containing the sample extract to a nitrogen blowdown device. Adjust the flow of nitrogen so that the surface of the solvent is just visibly disturbed.

Note: A large vortex in the solvent may cause analyte loss.

- 12.7.3** Lower the vial into a 45 °C water bath and continue concentrating.
 - 12.7.3.1** If the extract is to be concentrated to dryness for weight determination (Sections 12.4.1.8, 12.4.2.7, and 13.7.1.4), blow dry until a constant weight is obtained.
 - 12.7.3.2** If the extract is to be concentrated for injection into the GC/MS or the solvent is to be exchanged for extract cleanup, proceed as follows:
- 12.7.4** When the volume of the liquid is approximately 100 µL, add 2 to 3 mL of the desired solvent (methylene chloride for GPC and HPLC, or hexane for the other cleanups) and continue concentration to approximately 100 µL. Repeat the addition of solvent and concentrate once more.
- 12.7.5** If the extract is to be cleaned up by GPC, adjust the volume of the extract to 5.0 mL with methylene chloride. If the extract is to be cleaned up by HPLC, further concentrate the extract to 30 µL. Proceed with GPC or HPLC cleanup (Section 13.2 or 13.6, respectively).
- 12.7.6** If the extract is to be cleaned up by column chromatography (alumina, silica gel, Caropak/Celite, or Florisil), bring the final volume to 1.0 mL with hexane. Proceed with column cleanups (Sections 13.3 - 13.5 and 13.8).
- 12.7.7** If the extract is to be concentrated for injection into the GC/MS (Section 14), quantitatively

transfer the extract to a 0.3-mL conical vial for final concentration, rinsing the larger vial with hexane and adding the rinse to the conical vial. Reduce the volume to approximately 100 μ L. Add 10 μ L of nonane to the vial, and evaporate the solvent to the level of the nonane. Seal the vial and label with the sample number. Store in the dark at room temperature until ready for GC/MS analysis. If GC/MS analysis will not be performed on the same day, store the vial at <-10 °C.

13.0 Extract Cleanup

13.1 Cleanup may not be necessary for relatively clean samples (e.g., treated effluents, groundwater, drinking water). If particular circumstances require the use of a cleanup procedure, the analyst may use any or all of the procedures below or any other appropriate procedure. Before using a cleanup procedure, the analyst must demonstrate that the requirements of Section 9.2 can be met using the cleanup procedure. If only 2,3,7,8-TCDD and 2,3,7,8-TCDF are to be determined, the cleanup procedures may be optimized for isolation of these two compounds.

13.1.1 Gel permeation chromatography (Section 13.2) removes high molecular weight interferences that cause GC column performance to degrade. It should be used for all soil and sediment extracts and may be used for water extracts that are expected to contain high molecular weight organic compounds (e.g., polymeric materials, humic acids).

13.1.2 Acid, neutral, and basic silica gel (Section 13.3), alumina (Section 13.4), and Florisil (Section 13.8) are used to remove nonpolar and polar interferences. Alumina and Florisil are used to remove chlorodiphenyl ethers.

13.1.3 Carbopak/Celite (Section 13.5) is used to remove nonpolar interferences.

13.1.4 HPLC (Section 13.6) is used to provide specificity for the 2,3,7,8-substituted and other CDD and CDF isomers.

13.1.5 The anthropogenic isolation column (Section 13.7.1), acidified silica gel batch adsorption procedure (Section 13.7.2), and sulfuric acid and base back-extraction (Section 13.7.3) are used for removal of lipids from tissue samples.

13.2 Gel permeation chromatography (GPC).

13.2.1 Column packing.

13.2.1.1 Place 70 to 75 g of SX-3 Bio-beads (Section 6.7.1.1) in a 400- to 500-mL beaker.

13.2.1.2 Cover the beads with methylene chloride and allow to swell overnight (a minimum of 12 hours).

13.2.1.3 Transfer the swelled beads to the column (Section 6.7.1.1) and pump solvent through the column, from bottom to top, at 4.5 to 5.5 mL/minute prior to connecting the column to the detector.

13.2.1.4 After purging the column with solvent for 1 to 2 hours, adjust the column head pressure to 7 to 10 psig and purge for 4 to 5 hours to remove air. Maintain a head pressure of 7 to 10 psig. Connect the column to the detector (Section 6.7.1.4).

13.2.2 Column calibration.

13.2.2.1 Load 5 mL of the calibration solution (Section 7.4) into the sample loop.

13.2.2.2 Inject the calibration solution and record the signal from the detector. The elution

pattern will be corn oil, bis(2-ethyl hexyl)phthalate, pentachlorophenol, perylene, and sulfur.

13.2.2.3 Set the "dump time" to allow >85% removal of the corn oil and >85% collection of the phthalate.

13.2.2.4 Set the "collect time" to the peak minimum between perylene and sulfur.

13.2.2.5 Verify the calibration with the calibration solution after every 20 extracts. Calibration is verified if the recovery of the pentachlorophenol is greater than 85%. If calibration is not verified, the system shall be recalibrated using the calibration solution, and the previous 20 samples shall be re-extracted and cleaned up using the calibrated GPC system.

13.2.3 Extract cleanup—GPC requires that the column not be overloaded. The column specified in this method is designed to handle a maximum of 0.5 g of high molecular weight material in a 5-mL extract. If the extract is known or expected to contain more than 0.5 g, the extract is split into aliquots for GPC, and the aliquots are combined after elution from the column. The residue content of the extract may be obtained gravimetrically by evaporating the solvent from a 50- μ L aliquot.

13.2.3.1 Filter the extract or load through the filter holder (Section 6.7.1.3) to remove the particles. Load the 5.0-mL extract onto the column.

13.2.3.2 Elute the extract using the calibration data determined in Section 13.2.2. Collect the eluate in a clean 400- to 500-mL beaker.

13.2.3.3 Rinse the sample loading tube thoroughly with methylene chloride between extracts to prepare for the next sample.

13.2.3.4 If a particularly dirty extract is encountered, a 5.0-mL methylene chloride blank shall be run through the system to check for carry-over.

13.2.3.5 Concentrate the eluate per Section 12.6 and Section 12.7 for further cleanup or injection into the GC/MS.

13.3 Silica gel cleanup.

13.3.1 Place a glass-wool plug in a 15-mm ID chromatography column (Section 6.7.4.2). Pack the column bottom to top with: 1 g silica gel (Section 7.5.1.1), 4 g basic silica gel (Section 7.5.1.3), 1 g silica gel, 8 g acid silica gel (Section 7.5.1.2), 2 g silica gel, and 4 g granular anhydrous sodium sulfate (Section 7.2.1). Tap the column to settle the adsorbents.

13.3.2 Pre-elute the column with 50 to 100 mL of hexane. Close the stopcock when the hexane is within 1 mm of the sodium sulfate. Discard the eluate. Check the column for channeling. If channeling is present, discard the column and prepare another.

13.3.3 Apply the concentrated extract to the column. Open the stopcock until the extract is within 1 mm of the sodium sulfate.

13.3.4 Rinse the receiver twice with 1-mL portions of hexane and apply separately to the column. Elute the CDDs/CDFs with 100 mL hexane and collect the eluate.

13.3.5 Concentrate the eluate per Section 12.6 and 12.7 for further cleanup or injection into the HPLC or GC/MS.

- 13.3.6** For extracts of samples known to contain large quantities of other organic compounds (such as paper mill effluents), it may be advisable to increase the capacity of the silica gel column. This may be accomplished by increasing the strengths of the acid and basic silica gels. The acid silica gel (Section 7.5.1.2) may be increased in strength to as much as 44% w/w (7.9 g sulfuric acid added to 10 g silica gel). The basic silica gel (Section 7.5.1.3) may be increased in strength to as much as 33% w/w (50 mL 1N NaOH added to 100 g silica gel), or the potassium silicate (Section 7.5.1.4) may be used.

Note: The use of stronger acid silica gel (44% w/w) may lead to charring of organic compounds in some extracts. The charred material may retain some of the analytes and lead to lower recoveries of CDDs/CDFs. Increasing the strengths of the acid and basic silica gel may also require different volumes of hexane than those specified above to elute the analytes off the column. Therefore, the performance of the method after such modifications must be verified by the procedure in Section 9.2.

13.4 Alumina cleanup.

- 13.4.1** Place a glass-wool plug in a 15-mm ID chromatography column (Section 6.7.4.2).
- 13.4.2** If using acid alumina, pack the column by adding 6 g acid alumina (Section 7.5.2.1). If using basic alumina, substitute 6 g basic alumina (Section 7.5.2.2). Tap the column to settle the adsorbents.
- 13.4.3** Pre-elute the column with 50 to 100 mL of hexane. Close the stopcock when the hexane is within 1 mm of the alumina.
- 13.4.4** Discard the eluate. Check the column for channeling. If channeling is present, discard the column and prepare another.
- 13.4.5** Apply the concentrated extract to the column. Open the stopcock until the extract is within 1 mm of the alumina.
- 13.4.6** Rinse the receiver twice with 1-mL portions of hexane and apply separately to the column. Elute the interfering compounds with 100 mL hexane and discard the eluate.
- 13.4.7** The choice of eluting solvents will depend on the choice of alumina (acid or basic) made in Section 13.4.2.
- 13.4.7.1** If using acid alumina, elute the CDDs/CDFs from the column with 20 mL methylene chloride:hexane (20:80 v/v). Collect the eluate.
- 13.4.7.2** If using basic alumina, elute the CDDs/CDFs from the column with 20 mL methylene chloride:hexane (50:50 v/v). Collect the eluate.
- 13.4.8** Concentrate the eluate per Section 12.6 and 12.7 for further cleanup or injection into the HPLC or GC/MS.

13.5 Carbon column.

- 13.5.1** Cut both ends from a 10-mL disposable serological pipet (Section 6.7.3.2) to produce a 10-cm column. Fire-polish both ends and flare both ends if desired. Insert a glass-wool plug at one end and pack the column with 0.55 g of Carbowpak/Celite (Section 7.5.3.3) to form an adsorbent bed approximately 2 cm long. Insert a glass-wool plug on top of the bed to hold the adsorbent in place.

- 13.5.2** Pre-elute the column with 5 mL of toluene followed by 2 mL of methylene chloride:methanol:toluene (15:4:1 v/v), 1 mL of methylene chloride:cyclohexane (1:1 v/v), and 5 mL of hexane. If the flow rate of eluate exceeds 0.5 mL/minute, discard the column.
- 13.5.3** When the solvent is within 1 mm of the column packing, apply the sample extract to the column. Rinse the sample container twice with 1-mL portions of hexane and apply separately to the column. Apply 2 mL of hexane to complete the transfer.
- 13.5.4** Elute the interfering compounds with two 3-mL portions of hexane, 2 mL of methylene chloride:cyclohexane (1:1 v/v), and 2 mL of methylene chloride:methanol:toluene (15:4:1 v/v). Discard the eluate.
- 13.5.5** Invert the column and elute the CDDs/CDFs with 20 mL of toluene. If carbon particles are present in the eluate, filter through glass-fiber filter paper.
- 13.5.6** Concentrate the eluate per Section 12.6 and 12.7 for further cleanup or injection into the HPLC or GC/MS.
- 13.6 HPLC (Reference 6).
- 13.6.1** Column calibration.
- 13.6.1.1** Prepare a calibration standard containing the 2,3,7,8-substituted isomers and/or other isomers of interest at a concentration of approximately 500 pg/ μ L in methylene chloride.
- 13.6.1.2** Inject 30 μ L of the calibration solution into the HPLC and record the signal from the detector. Collect the eluant for reuse. The elution order will be the tetra-through octa- isomers.
- 13.6.1.3** Establish the collection time for the tetra-isomers and for the other isomers of interest. Following calibration, flush the injection system with copious quantities of methylene chloride, including a minimum of five 50- μ L injections while the detector is monitored, to ensure that residual CDDs/CDFs are removed from the system.
- 13.6.1.4** Verify the calibration with the calibration solution after every 20 extracts. Calibration is verified if the recovery of the CDDs/CDFs from the calibration standard (Section 13.6.1.1) is 75 to 125% compared to the calibration (Section 13.6.1.2). If calibration is not verified, the system shall be recalibrated using the calibration solution, and the previous 20 samples shall be re-extracted and cleaned up using the calibrated system.
- 13.6.2** Extract cleanup—HPLC requires that the column not be overloaded. The column specified in this method is designed to handle a maximum of 30 μ L of extract. If the extract cannot be concentrated to less than 30 μ L, it is split into fractions and the fractions are combined after elution from the column.
- 13.6.2.1** Rinse the sides of the vial twice with 30 μ L of methylene chloride and reduce to 30 μ L with the evaporation apparatus (Section 12.7).
- 13.6.2.2** Inject the 30 μ L extract into the HPLC.
- 13.6.2.3** Elute the extract using the calibration data determined in Section 13.6.1. Collect the fraction(s) in a clean 20-mL concentrator tube containing 5 mL of

hexane:acetone (1:1 v/v).

13.6.2.4 If an extract containing greater than 100 ng/mL of total CDD or CDF is encountered, a 30- μ L methylene chloride blank shall be run through the system to check for carry-over.

13.6.2.5 Concentrate the eluate per Section 12.7 for injection into the GC/MS.

13.7 Cleanup of tissue lipids—Lipids are removed from the Soxhlet extract using either the anthropogenic isolation column (Section 13.7.1) or acidified silica gel (Section 13.7.2), or are removed from the HCl digested extract using sulfuric acid and base back-extraction (Section 13.7.3).

13.7.1 Anthropogenic isolation column (References 22 and 27)—Used for removal of lipids from the Soxhlet/SDS extraction (Section 12.4.1).

13.7.1.1 Prepare the column as given in Section 7.5.4.

13.7.1.2 Pre-elute the column with 100 mL of hexane. Drain the hexane layer to the top of the column, but do not expose the sodium sulfate.

13.7.1.3 Load the sample and rinses (Section 12.4.1.9.2) onto the column by draining each portion to the top of the bed. Elute the CDDs/CDFs from the column into the apparatus used for concentration (Section 12.4.1.7) using 200 mL of hexane.

13.7.1.4 Concentrate the cleaned-up extract (Sections 12.6-12.7) to constant weight per Section 12.7.3.1. If more than 500 mg of material remains, repeat the cleanup using a fresh anthropogenic isolation column.

13.7.1.5 Redissolve the extract in a solvent suitable for the additional cleanups to be used (Section 13.2-13.6 and 13.8).

13.7.1.6 Spike 1.0 mL of the cleanup standard (Section 7.11) into the residue/solvent.

13.7.1.7 Clean up the extract using the procedures in Sections 13.2-13.6 and 13.8. Alumina (Section 13.4) or Florisil (Section 13.8) and carbon (Section 13.5) are recommended as minimum additional cleanup steps.

13.7.1.8 Following cleanup, concentrate the extract to 10 μ L as described in Section 12.7 and proceed with the analysis in Section 14.

13.7.2 Acidified silica gel (Reference 28)—Procedure alternate to the anthropogenic isolation column (Section 13.7.1) that is used for removal of lipids from the Soxhlet/SDS extraction (Section 12.4.1).

13.7.2.1 Adjust the volume of hexane in the bottle (Section 12.4.1.9.2) to approximately 200 mL.

13.7.2.2 Spike 1.0 mL of the cleanup standard (Section 7.11) into the residue/solvent.

13.7.2.3 Drop the stirring bar into the bottle, place the bottle on the stirring plate, and begin stirring.

13.7.2.4 Add 30-100 g of acid silica gel (Section 7.5.1.2) to the bottle while stirring, keeping the silica gel in motion. Stir for 2 to 3 hours.

Note: 30 grams of silica gel should be adequate for most samples and will minimize contamination from this source

- 13.7.2.5** After stirring, pour the extract through approximately 10 g of granular anhydrous sodium sulfate (Section 7.2.1) contained in a funnel with glass-fiber filter into a macro concentration device (Section 12.6). Rinse the bottle and sodium sulfate with hexane to complete the transfer.
- 13.7.2.6** Concentrate the extract per Sections 12.6-12.7 and clean up the extract using the procedures in Sections 13.2-13.6 and 13.8. Alumina (Section 13.4) or Florisil (Section 13.8) and carbon (Section 13.5) are recommended as minimum additional cleanup steps.
- 13.7.3** Sulfuric acid and base back-extraction—Used with HCl digested extracts (Section 12.4.2).
 - 13.7.3.1** Spike 1.0 mL of the cleanup standard (Section 7.11) into the residue/solvent (Section 12.4.2.8.2).
 - 13.7.3.2** Add 10 mL of concentrated sulfuric acid to the bottle. Immediately cap and shake 1 to 3 times. Loosen cap in a hood to vent excess pressure. Cap and shake the bottle so that the residue/solvent is exposed to the acid for a total time of approximately 45 seconds.
 - 13.7.3.3** Decant the hexane into a 250-mL separatory funnel making sure that no acid is transferred. Complete the quantitative transfer with several hexane rinses.
 - 13.7.3.4** Back extract the solvent/residue with 50 mL of potassium hydroxide solution per Section 12.5.2, followed by two reagent water rinses.
 - 13.7.3.5** Drain the extract through a filter funnel containing approximately 10 g of granular anhydrous sodium sulfate in a glass-fiber filter into a macro concentration device (Section 12.6).
 - 13.7.3.6** Concentrate the cleaned-up extract to a volume suitable for the additional cleanups given in Sections 13.2-13.6 and 13.8. Gel permeation chromatography (Section 13.2), alumina (Section 13.4) or Florisil (Section 13.8), and Carbopak/Celite (Section 13.5) are recommended as minimum additional cleanup steps.
 - 13.7.3.7** Following cleanup, concentrate the extract to 10 μ L as described in Section 12.7 and proceed with analysis per Section 14.
- 13.8** Florisil cleanup (Reference 29).
 - 13.8.1** Pre-elute the activated Florisil column (Section 7.5.3) with 10 mL of methylene chloride followed by 10 mL of hexane:methylene chloride (98:2 v/v) and discard the solvents.
 - 13.8.2** When the solvent is within 1 mm of the packing, apply the sample extract (in hexane) to the column. Rinse the sample container twice with 1-mL portions of hexane and apply to the column.
 - 13.8.3** Elute the interfering compounds with 20 mL of hexane:methylene chloride (98:2) and discard the eluate.
 - 13.8.4** Elute the CDDs/CDFs with 35 mL of methylene chloride and collect the eluate. Concentrate the eluate per Sections 12.6-12.7 for further cleanup or for injection into the HPLC or GC/MS.

14.0 GC-MS/MS Analysis

- 14.1 Establish the operating conditions given in Section 10.1.
- 14.2 Add 10 μL of the appropriate internal standard solution (Section 7.12) to the sample extract immediately prior to injection to minimize the possibility of loss by evaporation, adsorption, or reaction. If an extract is to be reanalyzed and evaporation has occurred, do not add more instrument internal standard solution. Rather, bring the extract back to its previous volume (e.g., 19 μL) with pure nonane only (18 μL if 2 μL injections are used).
- 14.3 Inject 1.0 μL of the concentrated extract containing the internal standard solution, using on-column or splitless injection. The volume injected must be identical to the volume used for calibration (Section 10). Start the GC column initial isothermal hold upon injection. Start MS data collection after the solvent peak elutes. Stop data collection after the OCDD and OCDF have eluted. If only 2,3,7,8-TCDD and 2,3,7,8-TCDF are to be determined, stop data collection after elution of these compounds. Return the column to the initial temperature for analysis of the next extract or standard.

15.0 System and Laboratory Performance

- 15.1 At the beginning of each 12-hour shift during which analyses are performed, GC-MS/MS system performance and calibration are verified for all CDDs/CDFs and labeled compounds. For these tests, analysis of the CS3 calibration verification (VER) standard (Section 7.13 and Table 4) and the isomer specificity test standards (Section 7.15 and Table 5) shall be used to verify all performance criteria. Adjustment and/or recalibration (Section 10) shall be performed until all performance criteria are met. Only after all performance criteria are met may samples, blanks, IPRs, and OPRs be analyzed.
- 15.2 MS calibration—A calibration check must be performed before any analysis is performed. See Section 10.1.2 for calibration procedures and criteria. Calibration checks must be performed at the beginning and of each 12-hour shift according to procedures in Section 10.1.2. Corrective actions must be implemented whenever the required resolution and mass accuracy is not achieved.
- 15.3 Calibration verification.
 - 15.3.1 Inject the VER standard using the procedure in Section 14.
 - 15.3.2 The MRM product ion area ratios for all CDDs/CDFs shall be within the limits in Table 9; otherwise, the mass spectrometer shall be adjusted until the ratios fall within the limits specified, and the verification test shall be repeated. If the adjustment alters the resolution of the mass spectrometer, resolution shall be verified (Section 10.1.2) prior to repeat of the verification test.
 - 15.3.3 The peaks representing each CDD/CDF and labeled compound in the VER standard must be present with S/N of at least 10; otherwise, the mass spectrometer shall be adjusted and the verification test repeated.
 - 15.3.4 Compute the concentration of each CDD/CDF compound by isotope dilution (Section 10.5) for those compounds that have labeled analogs (Table 1). Compute the concentration of the labeled compounds by the internal standard method (Section 10.6). These concentrations are computed based on the calibration data in Section 10.

15.3.5 For each compound, compare the concentration with the calibration verification limit in Table 6. If only 2,3,7,8-TCDD and 2,3,7,8-TCDF are to be determined, compare the concentration to the limit in Table 6a. If all compounds meet the acceptance criteria, calibration has been verified and analysis of standards and sample extracts may proceed. If, however, any compound fails its respective limit, the measurement system is not performing properly for that compound. In this event, prepare a fresh calibration standard or correct the problem causing the failure and repeat the resolution (Section 15.2) and verification (Section 15.3) tests, or recalibrate (Section 10).

15.4 Retention times and GC resolution.

15.4.1 Retention times.

15.4.1.1 Absolute—The absolute retention times of the $^{13}\text{C}_{12}$ -1,2,3,4-TCDD and $^{13}\text{C}_{12}$ -1,2,3,7,8,9-HxCDD GCMS internal standards in the verification test (Section 15.3) shall be within ± 15 seconds of the retention times obtained during calibration (Sections 10.2.1 and 10.2.4).

15.4.1.2 Relative—The relative retention times of CDDs/CDFs and labeled compounds in the verification test (Section 15.3) shall be within the limits given in Table 2.

15.4.2 GC resolution.

15.4.2.1 Inject the isomer specificity standards (Section 7.15) on their respective columns.

15.4.2.2 The valley height between 2,3,7,8-TCDD and the other tetra-dioxin isomers at the MRM transitions in Table 8 and between 2,3,7,8-TCDF and the other tetra-furan isomers at the MRM transitions in Table 8 shall not exceed 25% on their respective columns (Figures 6 and 7).

15.4.3 If the absolute retention time of any compound is not within the limits specified or if the 2,3,7,8-isomers are not resolved, the GC is not performing properly. In this event, adjust the GC and repeat the verification test (Section 15.3) or recalibrate (Section 10), or replace the GC column and either verify calibration or recalibrate.

15.5 Ongoing precision and recovery.

15.5.1 Analyze the extract of the ongoing precision and recovery (OPR) aliquot (Section 11.4.2.5, 11.5.4, 11.6.2, 11.7.4, or 11.8.3.2) prior to analysis of samples from the same batch.

15.5.2 Compute the concentration of each CDD/CDF by isotope dilution for those compounds that have labeled analogs (Section 10.5). Compute the concentration of 1,2,3,7,8,9-HxCDD, OCDF, and each labeled compound by the internal standard method (Section 10.6).

15.5.3 For each CDD/CDF and labeled compound, compare the concentration to the OPR limits given in Table 6. If only 2,3,7,8-TCDD and 2,3,7,8-TCDF are to be determined, compare the concentration to the limits in Table 6a. If all compounds meet the acceptance criteria, system performance is acceptable and analysis of blanks and samples may proceed. If, however, any individual concentration falls outside of the range given, the extraction/concentration processes are not being performed properly for that compound. In this event, correct the problem, re-prepare, extract, and clean up the sample batch and repeat the ongoing precision and recovery test (Section 15.5).

- 15.5.4** Add results that pass the specifications in Section 15.5.3 to initial and previous ongoing data for each compound in each matrix. Update QC charts to form a graphic representation of continued laboratory performance. Develop a statement of laboratory accuracy for each CDD/CDF in each matrix type by calculating the average percent recovery (R) and the standard deviation of percent recovery (S_R). Express the accuracy as a recovery interval from $R - 2S_R$ to $R + 2S_R$. For example, if $R = 95\%$ and $S_R = 5\%$, the accuracy is 85 to 105%.
- 15.6 Blank—Analyze the method blank extracted with each sample batch immediately following analysis of the OPR aliquot to demonstrate freedom from contamination and freedom from carryover from the OPR analysis. The results of the analysis of the blank must meet the specifications in Section 9.5.2 before sample analyses may proceed.

16.0 Qualitative Determination

A CDD, CDF, or labeled compound is identified in a standard, blank, or sample when all of the criteria in Sections 16.1 through 16.4 are met.

- 16.1 The signals for the two product ions of the MRM transitions in Table 8 must be present and must maximize within the same two seconds.
- 16.2 The signal-to-noise ratio (S/N) for the GC peak of each MRM transition product ion must be greater than or equal to 2.5 for each CDD or CDF detected in a sample extract, and greater than or equal to 10 for all CDDs/CDFs in the calibration standard (Sections 10.2.3 and 15.3.3).
- 16.3 The ratio of the integrated areas of the two MRM transition product ions specified in Table 8 must be within the limit in Table 9, or within ± 10 percent of the ratio in the midpoint (CS3) calibration or calibration verification (VER), whichever is most recent.
- 16.4 The relative retention time of the peak for a 2,3,7,8-substituted CDD or CDF must be within the limit in Table 2. The retention time of peaks representing non-2,3,7,8-substituted CDDs/CDFs must be within the retention time windows established in Section 10.3.
- 16.5 Confirmatory analysis—Isomer specificity for 2,3,7,8-TCDF cannot be achieved on the DB-5 column. Therefore, any sample in which 2,3,7,8-TCDF is identified by analysis on a DB-5 column must have a confirmatory analysis performed on a DB-225, SP-2330, or equivalent GC column. The operating conditions in Section 10.1.1 may be adjusted to optimize the analysis on the second GC column, but the GC-MS/MS must meet the mass resolution and calibration specifications in Section 10.
- 16.6 If the criteria for identification in Sections 16.1-16.5 are not met, the CDD or CDF has not been identified and the results may not be reported for regulatory compliance purposes. If interferences preclude identification, a new aliquot of sample must be extracted, further cleaned up, and analyzed.

17.0 Quantitative Determination

- 17.1 Isotope dilution quantitation—By adding a known amount of a labeled compound to every sample prior to extraction, correction for recovery of the CDD/CDF can be made because the CDD/CDF and

its labeled analog exhibit similar effects upon extraction, concentration, and gas chromatography. Relative response (RR) values are used in conjunction with the initial calibration data described in Section 10.5 to determine concentrations directly, so long as labeled compound spiking levels are constant, using the following equation:

$$C_{ex} (ng/nL) = \frac{A_n C_l}{A_l RR}$$

where:

A_n = The area of the primary quantification ion for the CDD/CDF in the sample extract.

A_l = The area of the primary quantification ion for the internal standard.

C_l = The concentration of the internal standard expected in the extract.

RR = The relative response factor for the compound determined during calibration.

C_{ex} = The concentration of the CDD/CDF in the extract.

- 17.1.1** Because of a potential interference, the labeled analog of OCDF is not added to the sample. Therefore, OCDF is quantitated against labeled OCDD. As a result, the concentration of OCDF is corrected for the recovery of the labeled OCDD. In instances where OCDD and OCDF behave differently during sample extraction, concentration, and cleanup procedures, this may decrease the accuracy of the OCDF results. However, given the low toxicity of this compound relative to the other dioxins and furans, the potential decrease in accuracy is not considered significant.
- 17.1.2** Because $^{13}\text{C}_{12}$ -1,2,3,7,8,9-HxCDD is used as an instrument internal standard (i.e., not added before extraction of the sample), it cannot be used to quantitate the 1,2,3,7,8,9-HxCDD by strict isotope dilution procedures. Therefore, 1,2,3,7,8,9-HxCDD is quantitated using the averaged response of the labeled analogs of the other two 2,3,7,8-substituted HxCDD's: 1,2,3,4,7,8-HxCDD and 1,2,3,6,7,8-HxCDD. As a result, the concentration of 1,2,3,7,8,9-HxCDD is corrected for the average recovery of the other two HxCDD's.
- 17.1.3** Any peaks representing non-2,3,7,8-substituted CDDs/CDFs are quantitated using an average of the response factors from all of the labeled 2,3,7,8- isomers at the same level of chlorination.

17.2 Internal standard quantitation and labeled compound recovery

17.2.1 Compute the concentrations of 1,2,3,7,8,9-HxCDD, OCDF, the ¹³C-labeled analogs and the ³⁷C-labeled cleanup standard in the extract using the response factors determined from the initial calibration data (Section 10.6) and the following equation:

$$C_{ex} \text{ (ng/nL)} = \frac{A_s C_{IS}}{A_{IS} RF}$$

where:

A_s = The measured area of the quantification ion for the CDD/CDF in the extract.

A_{IS} = The measured area of the quantification ion for the IS.

C_{IS} = The concentration of the IS in the calibration standard.

C_{ex} = The concentration of the CDD/CDF in the extract.

RF = The response factor for the compound determined during calibration.

Note: There is only one MRM transition for the ³⁷Cl-labeled standard.

17.2.2 Using the concentration in the extract determined above, compute the percent recovery of the ¹³C-labeled compounds and the ³⁷C-labeled cleanup standard using the following equation:

$$\text{Recovery (\%)} = \frac{\text{concentration found } (\mu\text{g/nL})}{\text{concentration spiked } (\mu\text{g/nL})} \times 100$$

17.3 The concentration of a CDD/CDF in the solid phase of the sample is computed using the concentration of the compound in the extract and the weight of the solids (Section 11.5.1), as follows:

$$\text{Concentration in solid (ng/kg)} = \frac{(C_{ex} \times V_{ex})}{W_s}$$

where:

C_{ex} = The concentration of the compound in the extract.

V_{ex} = The extract volume in mL.

W_s = The sample weight (dry weight) in kg.

- 17.4 The concentration of a CDD/CDF in the aqueous phase of the sample is computed using the concentration of the compound in the extract and the volume of water extracted (Section 11.4 or 11.5), as follows:

$$\text{Concentration in aqueous phase (pg/L)} = \frac{(C_{ex} \times V_{ex})}{V_s}$$

where:

C_{ex} = The concentration of the compound in the extract.

V_{ex} = The extract volume in mL.

V_s = The sample volume in liters.

- 17.5 If the MRM transition product ion response area at either primary or secondary transition for any compound exceeds the calibration range of the system, a smaller sample aliquot is extracted.
- 17.5.1** For aqueous samples containing 1% solids or less, dilute 100 mL, 10 mL, etc., of sample to 1 L with reagent water and re-prepare, extract, clean up, and analyze per Sections 11 - 14.
- 17.5.2** For samples containing greater than 1% solids, extract an amount of sample equal to 1/10, 1/100, etc., of the amount used in Section 11.5.1. Re-prepare, extract, clean up, and analyze per Sections 11-14.
- 17.5.3** If a smaller sample size will not be representative of the entire sample, dilute the sample extract by a factor of 10, adjust the concentration of the instrument internal standard to 100 pg/ μ L in the extract, and analyze an aliquot of this diluted extract by the internal standard method.
- 17.6 Results are reported to three significant figures for the CDDs/CDFs and labeled compounds found in all standards, blanks, and samples.
- 17.6.1** Reporting units and levels.
- 17.6.1.1** Aqueous samples—Report results in pg/L (parts-per-quadrillion).
- 17.6.1.2** Samples containing greater than 1% solids (soils, sediments, filter cake, compost)—Report results in ng/kg based on the dry weight of the sample. Report the percent solids so that the result may be corrected.
- 17.6.1.3** Tissues—Report results in ng/kg of wet tissue, not on the basis of the lipid content of the sample. Report the percent lipid content, so that the data user can calculate the concentration on a lipid basis if desired.
- 17.6.1.4** Reporting level.
- 17.6.1.4.1** Standards (VER, IPR, OPR) and samples—Report results at or above the minimum level (Table 2). Report results below the minimum level as not detected or as required by the regulatory authority.
- 17.6.1.4.2** Blanks—Report results above one-third the ML.
- 17.6.2** Results for CDDs/CDFs in samples that have been diluted are reported at the least dilute level at which the areas at the quantitation MRM product ions are within the calibration range (Section 17.5).

- 17.6.3** For CDDs/CDFs having a labeled analog, results are reported at the least dilute level at which the area at the quantitation MRM transition product ion is within the calibration range (Section 17.5) and the labeled compound recovery is within the normal range for the method (Section 9.3 and Tables 6, 6a, 7, and 7a).
- 17.6.4** Additionally, if requested, the total concentration of all isomers in an individual level of chlorination (i.e., total TCDD, total TCDF, total PeCDD, etc.) may be reported by summing the concentrations of all isomers identified in that level of chlorination, including both 2,3,7,8-substituted and non-2,3,7,8-substituted isomers.

18.0 Analysis of Complex Samples

- 18.1 Some samples may contain high levels (>10 ng/L; >1000 ng/kg) of the compounds of interest, interfering compounds, and/or polymeric materials. Some extracts will not concentrate to 10 μ L (Section 12.7); others may overload the GC column and/or mass spectrometer.
- 18.2 Analyze a smaller aliquot of the sample (Section 17.5) when the extract will not concentrate to 10 μ L after all cleanup procedures have been exhausted.
- 18.3 Chlorodiphenyl ethers—If chromatographic peaks are detected at the retention time of any CDDs/CDFs in any of MRM transition product ions being monitored for the chlorodiphenyl ethers (Table 8), cleanup procedures must be employed until these interferences are removed. Alumina (Section 13.4) and Florisil (Section 13.8) are recommended for removal of chlorodiphenyl ethers.
- 18.4 Recovery of labeled compounds—In most samples, recoveries of the labeled compounds will be similar to those from reagent water or from the alternate matrix (Section 7.6).
- 18.4.1** If the recovery of any of the labeled compounds is outside of the normal range (Table 7), a diluted sample shall be analyzed (Section 17.5).
- 18.4.2** If the recovery of any of the labeled compounds in the diluted sample is outside of normal range, the calibration verification standard (Section 7.13) shall be analyzed and calibration verified (Section 15.3).
- 18.4.3** If the calibration cannot be verified, a new calibration must be performed and the original sample extract reanalyzed.
- 18.4.4** If the calibration is verified and the diluted sample does not meet the limits for labeled compound recovery, the method does not apply to the sample being analyzed and the result may not be reported for regulatory compliance purposes. In this case, alternate extraction and cleanup procedures in this method must be employed to resolve the interference. If all cleanup procedures in this method have been employed and labeled compound recovery remains outside of the normal range, extraction and/or cleanup procedures that are beyond this scope of this method will be required to analyze these samples.

19.0 Pollution Prevention

- 19.1 The solvents used in this method pose little threat to the environment when managed properly. The solvent evaporation techniques used in this method are amenable to solvent recovery, and it is recommended that the laboratory recover solvents wherever feasible.
- 19.2 Standards should be prepared in volumes consistent with laboratory use to minimize disposal of standards.

20.0 Waste Management

- 20.1 It is the laboratory's responsibility to comply with all federal, state, and local regulations governing waste management, particularly the hazardous waste identification rules and land disposal restrictions, and to protect the air, water, and land by minimizing and controlling all releases from fume hoods and bench operations. Compliance is also required with any sewage discharge permits and regulations.
- 20.2 Samples containing HCl to pH <2 are hazardous and must be neutralized before being poured down a drain or must be handled as hazardous waste.
- 20.3 The CDDs/CDFs decompose above 800 °C. Low-level waste such as absorbent paper, tissues, animal remains, and plastic gloves may be burned in an appropriate incinerator. Gross quantities (milligrams) should be packaged securely and disposed of through commercial or governmental channels that are capable of handling extremely toxic wastes.
- 20.4 Liquid or soluble waste should be dissolved in methanol or ethanol and irradiated with ultraviolet light with a wavelength shorter than 290 nm for several days. Use F40 BL or equivalent lamps. Analyze liquid wastes and dispose of the solutions when the CDDs/CDFs can no longer be detected.
- 20.5 For further information on waste management, consult "The Waste Management Manual for Laboratory Personnel" and "Less is Better—Laboratory Chemical Management for Waste Reduction," available from the American Chemical Society's Department of Government Relations and Science Policy, 1155 16th Street N.W., Washington, D.C. 20036.

21.0 Method Performance

Method performance for Method 1613B was validated and performance specifications were developed using data from EPA's international interlaboratory validation study (References 30-31) and the EPA/paper industry Long-Term Variability Study of discharges from the pulp and paper industry (58 FR 66078). This alternate method meets all Method 1613B performance specifications.

22.0 References

- 1 Tondeur, Yves, "Method 8290: Analytical Procedures and Quality Assurance for Multimedia Analysis of Polychlorinated Dibenzo-*p*-dioxins and Dibenzofurans by High Resolution Gas Chromatography/High Resolution Mass Spectrometry," USEPA EMSL, Las Vegas, Nevada, June 1987.
- 2 "Measurement of 2,3,7,8-Tetrachlorinated Dibenzo-*p*-dioxin (TCDD) and 2,3,7,8-Tetrachlorinated Dibenzofuran (TCDF) in Pulp, Sludges, Process Samples and Wastewaters from Pulp and Paper Mills," Wright State University, Dayton, OH 45435, June 1988.
- 3 "NCASI Procedures for the Preparation and Isomer Specific Analysis of Pulp and Paper Industry Samples for 2,3,7,8-TCDD and 2,3,7,8-TCDF," National Council of the Paper Industry for Air and Stream Improvement Inc., 260 Madison Avenue, New York, NY 10016, Technical Bulletin No. 551, Pre-Release Copy, July 1988.
- 4 "Analytical Procedures and Quality Assurance Plan for the Determination of PCDD/PCDF in Fish," USEPA, Environmental Research Laboratory, 6201 Congdon Boulevard, Duluth, MN 55804, April 1988.
- 5 Tondeur, Yves, "Proposed GC/MS Methodology for the Analysis of PCDDs and PCDFs in Special Analytical Services Samples," Triangle Laboratories, Inc., 801-10 Capitola Dr, Research Triangle Park, NC 27713, January 1988; updated by personal communication September 1988.
- 6 Lamparski, L.L., and Nestruck, T.J., "Determination of Tetra-, Hexa-, Hepta-, and Octachlorodibenzo-*p*-dioxin Isomers in Particulate Samples at Parts per Trillion Levels," *Analytical Chemistry*, 52: 2045-2054, 1980.
- 7 Lamparski, L.L., and Nestruck, T.J., "Novel Extraction Device for the Determination of Chlorinated Dibenzo-*p*-dioxins (PCDDs) and Dibenzofurans (PCDFs) in Matrices Containing Water," *Chemosphere*, 19:27-31, 1989
- 8 Patterson, D.G., et. al. "Control of Interferences in the Analysis of Human Adipose Tissue for 2,3,7,8-Tetrachlorodibenzo-*p*-dioxin," *Environmental Toxicological Chemistry*, 5: 355-360, 1986.
- 9 Stanley, John S., and Sack, Thomas M., "Protocol for the Analysis of 2,3,7,8-Tetrachlorodibenzo-*p*-dioxin by High Resolution Gas Chromatography/High Resolution Mass Spectrometry," USEPA EMSL, Las Vegas, Nevada 89114, EPA 600/4-86-004, January 1986.
- 10 "Working with Carcinogens," Department of Health, Education, & Welfare, Public Health Service, Centers for Disease Control, NIOSH, Publication 77-206, August 1977, NTIS PB-277256.
- 11 "OSHA Safety and Health Standards, General Industry," OSHA 2206, 29 *CFR* 1910.
- 12 "Safety in Academic Chemistry Laboratories," ACS Committee on Chemical Safety, 1979.
- 13 "Standard Methods for the Examination of Water and Wastewater," 18th edition and later revisions, American Public Health Association, 1015 15th St, N.W., Washington, DC 20005, 1-35: Section 1090 (Safety), 1992.
- 14 "Method 613—2,3,7,8-Tetrachlorodibenzo-*p*-dioxin," 40 *CFR* 136 (49 *FR* 43234), October 26, 1984, Section 4.1.
- 15 Provost, L.P., and Elder, R.S., "Interpretation of Percent Recovery Data," *American Laboratory*, 15: 56-83, 1983.
- 16 "Standard Practice for Sampling Water," ASTM Annual Book of Standards, ASTM, 1916 Race Street, Philadelphia, PA 19103-1187, 1980.

- 17 "Methods 330.4 and 330.5 for Total Residual Chlorine," USEPA, EMSL, Cincinnati, OH 45268, EPA 600/4-79-020, March 1979.
- 18 "Handbook of Analytical Quality Control in Water and Wastewater Laboratories," USEPA EMSL, Cincinnati, OH 45268, EPA-600/4-79-019, March 1979.
- 19 Williams, Rick, letter to Bill Telliard, June 4, 1993, available from the EPA Sample Control Center operated by DynCorp Viar, Inc., 300 N Lee St, Alexandria VA 22314, 703-519-1140.
- 20 Barkowski, Sarah, Fax to Sue Price, August 6, 1992, available from the EPA Sample Control Center operated by DynCorp Viar, Inc., 300 N Lee St, Alexandria VA 22314, 703-519-1140.
- 21 "Analysis of Multi-media, Multi-concentration Samples for Dioxins and Furans, PCDD/PCDF Analyses Data Package", Narrative for Episode 4419, MRI Project No. 3091-A, op.cit. February 12, 1993, Available from the EPA Sample Control Center operated by DynCorp Viar Inc, 300 N Lee St, Alexandria, VA 22314 (703-519-1140).
- 22 "Analytical Procedures and Quality Assurance Plan for the Determination of PCDD/PCDF in Fish", U.S. Environmental Protection Agency, Environmental Research Laboratory, Duluth MN 55804, EPA/600/3-90/022, March 1990.
- 23 Afghan, B.K., Carron, J., Goulden, P.D., Lawrence, J., Leger, D., Onuska, F., Sherry, J., and Wilkenson, R.J., "Recent Advances in Ultratrace Analysis of Dioxins and Related Halogenated Hydrocarbons", *Can J. Chem.*, 65: 1086-1097, 1987.
- 24 Sherry, J.P., and Tse, H., "A Procedure for the Determination of Polychlorinated Dibenzo-*p*-dioxins in Fish", *Chemosphere*, 20: 865-872, 1990.
- 25 "Preliminary Fish Tissue Study", Results of Episode 4419, available from the EPA Sample Control Center operated by DynCorp Viar, Inc., 300 N Lee St, Alexandria, VA 22314, 703-519-1140.
- 26 Nestruck, Terry L., DOW Chemical Co., personal communication with D.R. Rushneck, April 8, 1993. Details available from the U.S. Environmental Protection Agency Sample Control Center operated by DynCorp Viar Inc, 300 N Lee St, Alexandria, VA 22314, 703-519-1140.
- 27 Barnstadt, Michael, "Big Fish Column", Triangle Laboratories of RTP, Inc., SOP 129-90, 27 March 27, 1992.
- 28 "Determination of Polychlorinated Dibenzo-*p*-Dioxins (PCDD) and Dibenzofurans (PCDF) in Environmental Samples Using EPA Method 1613", Chemical Sciences Department, Midwest Research Institute, 425 Volker Boulevard, Kansas City, MO 44110-2299, Standard Operating Procedure No. CS-153, January 15, 1992.
- 29 Ryan, John J., Raymonde Lizotte and William H. Newsome, *J. Chromatog.* 303 (1984) 351-360.
- 30 Telliard, William A., Harry B. McCarty, and Lynn S. Riddick, "Results of the Interlaboratory Validation Study of USEPA Method 1613 for the Analysis of Tetra- through Octachlorinated Dioxins and Furans by Isotope Dilution GC/MS," *Chemosphere*, 27, 41-46 (1993).
- 31 "Results of the International Interlaboratory Validation Study of USEPA Method 1613", October 1994, available from the EPA Sample Control Center operated by DynCorp Viar, Inc., 300 N Lee St, Alexandria, VA 22314, 703-519-1140.

23.0 Tables and Figures

Table 1. Chlorinated Dibenzo-*p*-dioxins and Furans Determined by Isotope Dilution and Internal Standard Gas Chromatography (GC) Coupled with Tandem Quadrupole Mass Spectrometry (GC-MS/MS)

CDDs/CDFs ¹	CAS Registry	Labeled Analog	CAS Registry
2,3,7,8-TCDD	1746-01-6	¹³ C ₁₂ -2,3,7,8-TCDD ³⁷ Cl ₄ -2,3,7,8-TCDD	76523-40-5 85508-50-5
Total TCDD	41903-57-5	—	—
2,3,7,8-TCDF	51207-31-9	¹³ C ₁₂ -2,3,7,8-TCDF	89059-46-1
Total-TCDF	55722-27-5	—	—
1,2,3,7,8-PeCDD	40321-76-4	¹³ C ₁₂ -1,2,3,7,8-PeCDD	109719-79-1
Total-PeCDD	36088-22-9	—	—
1,2,3,7,8-PeCDF	57117-41-6	¹³ C ₁₂ -1,2,3,7,8-PeCDF	109719-77-9
2,3,4,7,8-PeCDF	57117-31-4	¹³ C ₁₂ -2,3,4,7,8-PeCDF	116843-02-8
Total-PeCDF	30402-15-4	—	—
1,2,3,4,7,8-HxCDD	39227-28-6	¹³ C ₁₂ -1,2,3,4,7,8-HxCDD	109719-80-4
1,2,3,6,7,8-HxCDD	57653-85-7	¹³ C ₁₂ -1,2,3,6,7,8-HxCDD	109719-81-5
1,2,3,7,8,9-HxCDD	19408-74-3	¹³ C ₁₂ -1,2,3,7,8,9-HxCDD	109719-82-6
Total-HxCDD	34465-46-8	—	—
1,2,3,4,7,8-HxCDF	70648-26-9	¹³ C ₁₂ -1,2,3,4,7,8-HxCDF	114423-98-2
1,2,3,6,7,8-HxCDF	57117-44-9	¹³ C ₁₂ -1,2,3,6,7,8-HxCDF	116843-03-9
1,2,3,7,8,9-HxCDF	72918-21-9	¹³ C ₁₂ -1,2,3,7,8,9-HxCDF	116843-04-0
2,3,4,6,7,8-HxCDF	60851-34-5	¹³ C ₁₂ -2,3,4,6,7,8-HxCDF	116843-05-1
Total-HxCDF	55684-94-1	—	—
1,2,3,4,6,7,8-HpCDD	35822-46-9	¹³ C ₁₂ -1,2,3,4,6,7,8-HpCDD	109719-83-7
Total-HpCDD	37871-00-4	—	—
1,2,3,4,6,7,8-HpCDF	67562-39-4	¹³ C ₁₂ -1,2,3,4,6,7,8-HpCDF	109719-84-8
1,2,3,4,7,8,9-HpCDF	55673-89-7	¹³ C ₁₂ -1,2,3,4,7,8,9-HpCDF	109719-94-0
Total-HpCDF	38998-75-3	—	—
OCDD	3268-87-9	¹³ C ₁₂ -OCDD	114423-97-1
OCDF	39001-02-0	not used	—

¹ Chlorinated dibenzo-*p*-dioxins and chlorinated dibenzofurans

TCDD = Tetrachlorodibenzo-*p*-dioxin

PeCDD = Pentachlorodibenzo-*p*-dioxin

HxCDD = Hexachlorodibenzo-*p*-dioxin

HpCDD = Heptachlorodibenzo-*p*-dioxin

OCDD = Octachlorodibenzo-*p*-dioxin

TCDF = Tetrachlorodibenzofuran

PeCDF = Pentachlorodibenzofuran

HxCDF = Hexachlorodibenzofuran

HpCDF = Heptachlorodibenzofuran

OCDF = Octachlorodibenzofuran

Table 2. Retention Time References, Quantitation References, Relative Retention Times, and Minimum Levels for CDDs and CDFs

CDD/CDF	Retention time and quantitation reference	Relative retention time	Minimum level ¹		
			Water (pg/L; ppq)	Solid (ng/kg; ppt)	Extract (pg/μL; ppb)
<i>Compounds using ¹³C₁₂-1,2,3,4-TCDD as the injection internal standard</i>					
2,3,7,8-TCDF	¹³ C ₁₂ -2,3,7,8-TCDF	0.999–1.003	10	1	0.5
2,3,7,8-TCDD	¹³ C ₁₂ -2,3,7,8-TCDD	0.999–1.002	10	1	0.5
1,2,3,7,8-PeCDF	¹³ C ₁₂ -1,2,3,7,8-PeCDF	0.999–1.002	50	5	2.5
2,3,4,7,8-PeCDF	¹³ C ₁₂ -2,3,4,7,8-PeCDF	0.999–1.002	50	5	2.5
1,2,3,7,8-PeCDD	¹³ C ₁₂ -1,2,3,7,8-PeCDD	0.999–1.002	50	5	2.5
¹³ C ₁₂ -2,3,7,8-TCDF	¹³ C ₁₂ -1,2,3,4-TCDD	0.923–1.103			
¹³ C ₁₂ -2,3,7,8-TCDD	¹³ C ₁₂ -1,2,3,4-TCDD	0.976–1.043			
³⁷ Cl ₄ -2,3,7,8-TCDD	¹³ C ₁₂ -1,2,3,4-TCDD	0.989–1.052			
¹³ C ₁₂ -1,2,3,7,8-PeCDF	¹³ C ₁₂ -1,2,3,4-TCDD	1.000–1.425			
¹³ C ₁₂ -2,3,4,7,8-PeCDF	¹³ C ₁₂ -1,2,3,4-TCDD	1.011–1.526			
¹³ C ₁₂ -1,2,3,7,8-PeCDD	¹³ C ₁₂ -1,2,3,4-TCDD	1.000–1.567			
<i>Compounds using ¹³C₁₂-1,2,3,7,8,9-HxCDD as the injection internal standard</i>					
1,2,3,4,7,8-HxCDF	¹³ C ₁₂ -1,2,3,4,7,8-HxCDF	0.999–1.001	50	5	2.5
1,2,3,6,7,8-HxCDF	¹³ C ₁₂ -1,2,3,6,7,8-HxCDF	0.997–1.005	50	5	2.5
1,2,3,7,8,9-HxCDF	¹³ C ₁₂ -1,2,3,7,8,9-HxCDF	0.999–1.001	50	5	2.5
2,3,4,6,7,8-HxCDF	¹³ C ₁₂ -2,3,4,6,7,8-HxCDF	0.999–1.001	50	5	2.5
1,2,3,4,7,8-HxCDD	¹³ C ₁₂ -1,2,3,4,7,8-HxCDD	0.999–1.001	50	5	2.5
1,2,3,6,7,8-HxCDD	¹³ C ₁₂ -1,2,3,6,7,8-HxCDD	0.998–1.004	50	5	2.5
1,2,3,7,8,9-HxCDD	— ²	1.000–1.019	50	5	2.5
1,2,3,4,6,7,8-HpCDF	¹³ C ₁₂ -1,2,3,4,6,7,8-HpCDF	0.999–1.001	50	5	2.5
1,2,3,4,7,8,9-HpCDF	¹³ C ₁₂ -1,2,3,4,7,8,9-HpCDF	0.999–1.001	50	5	2.5
1,2,3,4,6,7,8-HpCDD	¹³ C ₁₂ -1,2,3,4,6,7,8-HpCDD	0.999–1.001	50	5	2.5
OCDF	¹³ C ₁₂ -OCDD	0.999–1.008	100	10	5.0
OCDD	¹³ C ₁₂ -OCDD	0.999–1.001	100	10	5.0
¹³ C ₁₂ -1,2,3,4,7,8-HxCDF	¹³ C ₁₂ -1,2,3,7,8,9-HxCDD	0.944–0.970			
¹³ C ₁₂ -1,2,3,6,7,8-HxCDF	¹³ C ₁₂ -1,2,3,7,8,9-HxCDD	0.949–0.975			
¹³ C ₁₂ -1,2,3,7,8,9-HxCDF	¹³ C ₁₂ -1,2,3,7,8,9-HxCDD	0.977–1.047			
¹³ C ₁₂ -2,3,4,6,7,8-HxCDF	¹³ C ₁₂ -1,2,3,7,8,9-HxCDD	0.959–1.021			
¹³ C ₁₂ -1,2,3,4,7,8-HxCDD	¹³ C ₁₂ -1,2,3,7,8,9-HxCDD	0.977–1.000			
¹³ C ₁₂ -1,2,3,6,7,8-HxCDD	¹³ C ₁₂ -1,2,3,7,8,9-HxCDD	0.981–1.003			
¹³ C ₁₂ -1,2,3,4,6,7,8-HpCDF	¹³ C ₁₂ -1,2,3,7,8,9-HxCDD	1.043–1.085			
¹³ C ₁₂ -1,2,3,4,7,8,9-HpCDF	¹³ C ₁₂ -1,2,3,7,8,9-HxCDD	1.057–1.151			
¹³ C ₁₂ -1,2,3,4,6,7,8-HpCDD	¹³ C ₁₂ -1,2,3,7,8,9-HxCDD	1.086–1.110			
¹³ C ₁₂ -OCDD	¹³ C ₁₂ -1,2,3,7,8,9-HxCDD	1.032–1.311			

¹ The Minimum Level (ML) for each analyte is defined as the level at which the entire analytical system must give a recognizable signal and acceptable calibration point. It is equivalent to the concentration of the lowest calibration standard, assuming that all method-specified sample weights, volumes, and cleanup procedures have been employed.

² The retention time reference for 1,2,3,7,8,9-HxCDD is ¹³C₁₂-1,2,3,6,7,8-HxCDD, and 1,2,3,7,8,9-HxCDD is quantified using the averaged responses for ¹³C₁₂-1,2,3,4,7,8-HxCDD and ¹³C₁₂-1,2,3,6,7,8-HxCDD.

Table 3. Concentration of Stock and Spiking Solutions Containing CDDs/CDFs and Labeled Compounds

CDD/CDF	Labeled compound stock solution ¹ (ng/mL)	Labeled compound spiking solution ² (ng/mL)	PAR stock solution ³ (ng/mL)	PAR spiking solution ⁴ (ng/mL)
2,3,7,8-TCDD	—	—	40	0.8
2,3,7,8-TCDF	—	—	40	0.8
1,2,3,7,8-PeCDD	—	—	200	4
1,2,3,7,8-PeCDF	—	—	200	4
2,3,4,7,8-PeCDF	—	—	200	4
1,2,3,4,7,8-HxCDD	—	—	200	4
1,2,3,6,7,8-HxCDD	—	—	200	4
1,2,3,7,8,9-HxCDD	—	—	200	4
1,2,3,4,7,8-HxCDF	—	—	200	4
1,2,3,6,7,8-HxCDF	—	—	200	4
1,2,3,7,8,9-HxCDF	—	—	200	4
2,3,4,6,7,8-HxCDF	—	—	200	4
1,2,3,4,6,7,8-HpCDD	—	—	200	4
1,2,3,4,6,7,8-HpCDF	—	—	200	4
1,2,3,4,7,8,9-HpCDF	—	—	200	4
OCDD	—	—	400	8
OCDF	—	—	400	8
¹³ C ₁₂ -2,3,7,8-TCDD	100	2	—	—
¹³ C ₁₂ -2,3,7,8-TCDF	100	2	—	—
¹³ C ₁₂ -1,2,3,7,8-PeCDD	100	2	—	—
¹³ C ₁₂ -1,2,3,7,8-PeCDF	100	2	—	—
¹³ C ₁₂ -2,3,4,7,8-PeCDF	100	2	—	—
¹³ C ₁₂ -1,2,3,4,7,8-HxCDD	100	2	—	—
¹³ C ₁₂ -1,2,3,6,7,8-HxCDD	100	2	—	—
¹³ C ₁₂ -1,2,3,4,7,8-HxCDF	100	2	—	—
¹³ C ₁₂ -1,2,3,6,7,8-HxCDF	100	2	—	—
¹³ C ₁₂ -1,2,3,7,8,9-HxCDF	100	2	—	—
¹³ C ₁₂ -2,3,4,6,7,8-HxCDF	100	2	—	—
¹³ C ₁₂ -1,2,3,4,6,7,8-HpCDD	100	2	—	—
¹³ C ₁₂ -1,2,3,4,6,7,8-HpCDF	100	2	—	—
¹³ C ₁₂ -1,2,3,4,7,8,9-HpCDF	100	2	—	—
¹³ C ₁₂ -OCDD	200	4	—	—
CDD/CDF	Labeled compound stock solution ¹ (ng/mL)	Labeled compound spiking solution ² (ng/mL)	PAR stock solution ³ (ng/mL)	PAR spiking solution ⁴ (ng/mL)
Concentration (ng/ml)				
<i>Cleanup Standard⁵</i>				
³⁷ Cl ₄ -2,3,7,8-TCDD	0.8			
<i>Internal Standards⁶</i>				
¹³ C ₁₂ -1,2,3,4-TCDD	200			
¹³ C ₁₂ -1,2,3,7,8,9-HxCDD	200			

¹ Section 7.10 – prepared in nonane and diluted to prepare spiking solution.

² Section 7.10.3 – prepared in acetone from stock solution daily.

³ Section 7.9 – prepared in nonane and diluted to prepare spiking solution.

⁴ Section 7.14 – prepared in acetone from stock solution daily.

⁵ Section 7.11 – prepared in nonane and added to extract prior to cleanup.

⁶ Section 7.12 – prepared in nonane and added to the concentrated extract immediately prior to injection into the GC (Section 14.2).

Table 4. Concentration of CDDs/CDFs in Calibration and Calibration Verification Solutions

CDD/CDF	CS1 (ng/mL)	CS2 (ng/mL)	VER ¹ CS3 (ng/mL)	CS4 (ng/mL)	CS5 (ng/mL)
2,3,7,8-TCDD	0.5	2	10	40	200
2,3,7,8-TCDF	0.5	2	10	40	200
1,2,3,7,8-PeCDD	2.5	10	50	200	1000
1,2,3,7,8-PeCDF	2.5	10	50	200	1000
2,3,4,7,8-PeCDF	2.5	10	50	200	1000
1,2,3,4,7,8-HxCDD	2.5	10	50	200	1000
1,2,3,6,7,8-HxCDD	2.5	10	50	200	1000
1,2,3,7,8,9-HxCDD	2.5	10	50	200	1000
1,2,3,4,7,8-HxCDF	2.5	10	50	200	1000
1,2,3,6,7,8-HxCDF	2.5	10	50	200	1000
1,2,3,7,8,9-HxCDF	2.5	10	50	200	1000
2,3,4,6,7,8-HxCDF	2.5	10	50	200	1000
1,2,3,4,6,7,8-HpCDD	2.5	10	50	200	1000
1,2,3,4,6,7,8-HpCDF	2.5	10	50	200	1000
1,2,3,4,7,8,9-HpCDF	2.5	10	50	200	1000
OCDD	5.0	20	100	400	2000
OCDF	5.0	20	100	400	2000
¹³ C ₁₂ -2,3,7,8-TCDD	100	100	100	100	100
¹³ C ₁₂ -2,3,7,8-TCDF	100	100	100	100	100
¹³ C ₁₂ -1,2,3,7,8-PeCDD	100	100	100	100	100
¹³ C ₁₂ -PeCDF	100	100	100	100	100
¹³ C ₁₂ -2,3,4,7,8-PeCDF	100	100	100	100	100
¹³ C ₁₂ -1,2,3,4,7,8-HxCDD	100	100	100	100	100
¹³ C ₁₂ -1,2,3,6,7,8-HxCDD	100	100	100	100	100
¹³ C ₁₂ -1,2,3,4,7,8-HxCDF	100	100	100	100	100
¹³ C ₁₂ -1,2,3,6,7,8-HxCDF	100	100	100	100	100
¹³ C ₁₂ -1,2,3,7,8,9-HxCDF	100	100	100	100	100
¹³ C ₁₂ -1,2,3,4,6,7,8-HpCDD	100	100	100	100	100
¹³ C ₁₂ -1,2,3,4,6,7,8-HpCDF	100	100	100	100	100
¹³ C ₁₂ -1,2,3,4,7,8,9-HpCDF	100	100	100	100	100
¹³ C ₁₂ -OCDD	200	200	200	200	200
<i>Cleanup Standard</i>					
³⁷ Cl ₄ -2,3,7,8-TCDD	0.5	2	10	40	200
<i>Internal Standards</i>					
¹³ C ₁₂ -1,2,3,4-TCDD	100	100	100	100	100
¹³ C ₁₂ -1,2,3,7,8,9-HxCDD	100	100	100	100	100

¹ Section 15.3, calibration verification solution.

Table 5. GC Retention Time Window Defining Solution and Isomer Specificity Test Standard (Section 7.15)

DB-5 Column GC Retention-Time Window Defining Solution		
CDD/CDF	First eluted	Last eluted
TCDF	1,3,6,8-	1,2,8,9-
TCDD	1,3,6,8-	1,2,8,9-
PeCDF	1,3,4,6,8-	1,2,3,8,9-
PeCDD	1,2,4,7,9-	1,2,3,8,9-
HxCDF	1,2,3,4,6,8-	1,2,3,4,8,9-
HxCDD	1,2,4,6,7,9-	1,2,3,4,6,7-
HpCDF	1,2,3,4,6,7,8-	1,2,3,4,7,8,9-
HpCDD	1,2,3,4,6,7,9-	1,2,3,4,6,7,8-

DB-5 Column TCDD Specificity Test Standard

1,2,3,7+1,2,3,8-TCDD

2,3,7,8-TCDD

1,2,3,9-TCDD

DB-225 Column TCDF Isomer Specificity Test Standard

2,3,4,7-TCDF

2,3,7,8-TCDF

1,2,3,9-TCDF

Table 6. Acceptance Criteria for Performance Tests when All CDDs/CDFs are Tested¹

Target Analytes	IPR			OPR		VER	
	%RSD	Low (%)	High (%)	Low (%)	High (%)	Low (%)	High (%)
2,3,7,8-TCDD	28	83	129	67	158	78	129
1,2,3,7,8-PeCDD	15	76	132	70	142	78	130
1,2,3,4,7,8-HxCDD	19	78	152	70	164	78	128
1,2,3,6,7,8-HxCDD	15	84	124	76	134	78	128
1,2,3,7,8,9-HxCDD	22	74	142	64	162	82	122
1,2,3,4,6,7,8-HpCDD	15	76	130	70	140	86	116
OCDD	19	89	127	78	144	79	126
2,3,7,8-TCDF	20	87	137	75	158	84	120
1,2,3,7,8-PeCDF	15	86	124	80	134	82	120
2,3,4,7,8-PeCDF	17	72	150	68	160	82	122
1,2,3,4,7,8-HxCDF	17	82	118	72	134	90	112
1,2,3,6,7,8-HxCDF	13	92	120	84	130	88	114
1,2,3,7,8,9-HxCDF	13	84	122	78	130	90	112
2,3,4,6,7,8-HxCDF	15	74	148	70	156	88	114
1,2,3,4,6,7,8-HpCDF	13	90	112	82	122	90	110
1,2,3,4,7,8,9-HpCDF	16	86	126	78	138	86	116
OCDF	27	74	146	63	170	63	159
¹³ C ₁₂ -2,3,7,8-TCDD	37	28	134	20	175	82	121
¹³ C ₁₂ -1,2,3,7,8-PeCDD	39	27	184	21	227	62	160
¹³ C ₁₂ -1,2,3,4,7,8-HxCDD	41	29	147	21	193	85	117
¹³ C ₁₂ -1,2,3,6,7,8-HxCDD	38	34	122	25	163	85	118
¹³ C ₁₂ -1,2,3,4,6,7,8-HpCDD	35	34	129	26	166	72	138
¹³ C ₁₂ -OCDD	48	20	138	13	199	48	208
¹³ C ₁₂ -2,3,7,8-TCDF	35	31	113	22	152	71	140
¹³ C ₁₂ -1,2,3,7,8-PeCDF	34	27	156	21	192	76	130
¹³ C ₁₂ -2,3,4,7,8-PeCDF	38	16	279	13	328	77	130
¹³ C ₁₂ -1,2,3,4,7,8-HxCDF	43	27	152	19	202	76	131
¹³ C ₁₂ -1,2,3,6,7,8-HxCDF	35	30	122	21	159	70	143
¹³ C ₁₂ -2,3,4,6,7,8-HxCDF	37	29	136	22	176	73	137
¹³ C ₁₂ -1,2,3,7,8,9-HxCDF	40	24	157	17	205	74	135
¹³ C ₁₂ -1,2,3,4,6,7,8-HpCDF	41	32	110	21	158	78	129
¹³ C ₁₂ -1,2,3,4,7,8,9-HpCDF	40	28	141	20	186	77	129
³⁷ Cl ₄ -2,3,7,8-TCDD	36	39	154	31	191	79	127

¹ All specifications are given as % Recovery or % RSD, regardless of matrix.



Table 6a. Acceptance Criteria for Performance Tests when Only Tetra Compounds are Tested¹

Target Analytes	IPR			OPR		VER	
	%RSD	Low (%)	High (%)	Low (%)	High (%)	Low %	High (%)
2,3,7,8-TCDD	27	87	124	73	146	82	123
2,3,7,8-TCDF	20	91	131	80	147	86	116
¹³ C ₁₂ -2,3,7,8-TCDD	35	32	115	25	141	85	117
¹³ C ₁₂ -2,3,7,8-TCDF	34	35	99	26	126	76	131
³⁷ Cl ₄ -2,3,7,8-TCDD	34	45	134	37	158	83	121

¹ All specifications are given as % recovery or % RSD, regardless of matrix.

Table 7. Labeled Compound Recovery in Samples when All CDDs/CDFs are Tested

Compound	Test conc	Labeled compound Recovery	
	(ng/mL)	(ng/mL) ¹	(%)
¹³ C ₁₂ -2,3,7,8-TCDD	100	25–164	25–164
¹³ C ₁₂ -2,3,7,8-TCDF	100	24–169	24–169
¹³ C ₁₂ -1,2,3,7,8-PeCDD	100	25–181	25–181
¹³ C ₁₂ -1,2,3,7,8-PeCDF	100	24–185	24–185
¹³ C ₁₂ -2,3,4,7,8-PeCDF	100	21–178	21–178
¹³ C ₁₂ -1,2,3,4,7,8-HxCDD	100	32–141	32–141
¹³ C ₁₂ -1,2,3,6,7,8,-HxCDD	100	28–130	28–130
¹³ C ₁₂ -1,2,3,4,7,8-HxCDF	100	26–152	26–152
¹³ C ₁₂ -1,2,3,6,7,8-HxCDF	100	26–123	26–123
¹³ C ₁₂ -1,2,3,7,8,9-HxCDF	100	29–147	29–147
¹³ C ₁₂ -2,3,4,6,7,8,-HxCDF	100	28–136	28–136
¹³ C ₁₂ -1,2,3,4,6,7,8-HpCDD	100	23–140	23–140
¹³ C ₁₂ -1,2,3,4,6,7,8-HpCDF	100	28–143	28–143
¹³ C ₁₂ -1,2,3,4,7,8,9-HpCDF	100	26–138	26–138
¹³ C ₁₂ -OCDD	200	34–313	17–157
³⁷ Cl ₄ -2,3,7,8-TCDD	10	3.5–19.7	35–197

¹ Specification given as concentration in the final extract, assuming a 20-μL volume.

Table 7a. Labeled Compound Recovery in Samples when Only Tetra Compounds are Tested

Compound	Test conc	Labeled compound recovery	
	(ng/mL)	(ng/mL) ¹	(%)
¹³ C ₁₂ -2,3,7,8-TCDD	100	31-137	31-137
¹³ C ₁₂ -2,3,7,8-TCDF	100	29-140	29-140
³⁷ Cl ₄ -2,3,7,8-TCDD	10	4.2–16.4	42–164

¹ Specification given as concentration in the final extract, assuming a 20-μL volume.

Table 8. Functions, MRM Transitions, Precursor Ion Types, and Elemental Compositions of the CDDs and CDFs

Group	MRM Transition (m/z)		Transition Precursor Species	Elemental composition of Transition Precursor	Substance ²
	Precursor	Product ⁵			
1	303.9	240.9	M	C ₁₂ H ₄ ³⁵ Cl ₄ O	TCDF
	305.9	242.9	M+2	C ₁₂ H ₄ ³⁵ Cl ₃ ³⁷ Cl O	TCDF
	315.9	252.0	M	¹³ C ₁₂ H ₄ ³⁵ Cl ₄ O	TCDF ³
	317.9	254.0	M+2	¹³ C ₁₂ H ₄ ³⁵ Cl ₃ ³⁷ Cl O	TCDF ³
	319.9	256.9	M	C ₁₂ H ₄ ³⁵ Cl ₄ O ₂	TCDD
	321.9	258.9	M+2	C ₁₂ H ₄ ³⁵ Cl ₃ ³⁷ Cl O ₂	TCDD
	327.9	262.9	M+8	C ₁₂ H ₄ ³⁷ Cl ₄ O ₂	TCDD ⁴
	331.9	268.0	M	¹³ C ₁₂ H ₄ ³⁵ Cl ₄ O ₂	TCDD ³
	333.9	270.0	M+2	¹³ C ₁₂ H ₄ ³⁵ Cl ₃ ³⁷ Cl O ₂	TCDD ³
	323.9	254.0	M	C ₁₂ H ₅ ³⁵ Cl ₅	PeCB ⁷
	357.8	287.9	M	C ₁₂ H ₄ ³⁵ Cl ₆	HxCB
	393.8	323.9	M+2	C ₁₂ H ₃ ³⁵ Cl ₆ ³⁷ Cl	HpCB
	375.8	305.9	M+2	C ₁₂ H ₄ ³⁵ Cl ₅ ³⁷ Cl O	HxCDFE
414.0	264.0	M	C ₈ F ₁₆ N	PFTBA ⁶	
2	337.9	274.9	M	C ₁₂ H ₃ ³⁵ Cl ₅ O	PeCDF
	339.9	276.9	M+2	C ₁₂ H ₃ ³⁵ Cl ₄ ³⁷ Cl O	PeCDF
	349.9	285.9	M	¹³ C ₁₂ H ₃ ³⁵ Cl ₅ O	PeCDF ³
	351.9	287.9	M+2	¹³ C ₁₂ H ₃ ³⁵ Cl ₄ ³⁷ Cl O	PeCDF ³
	353.9	290.9	M	C ₁₂ H ₃ ³⁵ Cl ₅ O ₂	PeCDD
	355.9	292.9	M+2	C ₁₂ H ₃ ³⁵ Cl ₄ ³⁷ Cl O ₂	PeCDD
	365.9	301.9	M	¹³ C ₁₂ H ₃ ³⁵ Cl ₅ O ₂	PeCDD ³
	367.9	303.9	M+2	¹³ C ₁₂ H ₃ ³⁵ Cl ₄ ³⁷ Cl O ₂	PeCDD ³
	323.9	254.0	M	C ₁₂ H ₅ ³⁵ Cl ₅	PeCB ⁷
	357.8	287.9	M	C ₁₂ H ₄ ³⁵ Cl ₆	HxCB ⁷
	393.8	323.9	M+2	C ₁₂ H ₃ ³⁵ Cl ₆ ³⁷ Cl	HpCB ⁷
	427.8	357.8	M+2	C ₁₂ H ₂ ³⁵ Cl ₇ ³⁷ Cl	OctaCB ⁷
	409.8	339.9	M+2	C ₁₂ H ₃ ³⁵ Cl ₆ ³⁷ Cl O	HpCDFE
414.0	264.0	M	C ₈ F ₁₆ N	PFTBA ⁶	
3	373.8	310.9	M+2	C ₁₂ H ₂ ³⁵ Cl ₅ ³⁷ Cl O	HxCDF
	375.8	312.9	M+4	C ₁₂ H ₂ ³⁵ Cl ₄ ³⁷ Cl ₂ O	HxCDF
	385.9	321.9	M+2	¹³ C ₁₂ H ₂ ³⁵ Cl ₅ ³⁷ Cl O	HxCDF ³
	387.9	323.9	M+4	¹³ C ₁₂ H ₂ ³⁵ Cl ₄ ³⁷ Cl ₂ O	HxCDF ³
	389.8	326.9	M+2	C ₁₂ H ₂ ³⁵ Cl ₅ ³⁷ Cl O ₂	HxCDD
	391.8	328.9	M+4	C ₁₂ H ₂ ³⁵ Cl ₄ ³⁷ Cl ₂ O ₂	HxCDD
	401.9	337.9	M+2	¹³ C ₁₂ H ₂ ³⁵ Cl ₅ ³⁷ Cl O ₂	HxCDD ³
	403.9	339.9	M+4	¹³ C ₁₂ H ₂ ³⁵ Cl ₄ ³⁷ Cl ₂ O ₂	HxCDD ³
	393.8	323.9	M+2	C ₁₂ H ₃ ³⁵ Cl ₆ ³⁷ Cl	HpCB ⁷
	427.8	357.8	M+2	C ₁₂ H ₂ ³⁵ Cl ₇ ³⁷ Cl	OctaCB ⁷
	461.7	391.8	M+2	C ₁₂ H ³⁵ Cl ₈ ³⁷ Cl	NonaCB ⁷
	445.8	373.8	M+4	C ₁₂ H ₂ ³⁵ Cl ₆ ³⁷ Cl ₂ O	OCDFE
	414.0	264.0	M	C ₈ F ₁₆ N	PFTBA ⁶
4	407.8	344.8	M+2	C ₁₂ H ³⁵ Cl ₆ ³⁷ Cl O	HpCDF
	409.8	346.8	M+4	C ₁₂ H ³⁵ Cl ₅ ³⁷ Cl ₂ O	HpCDF
	419.8	355.9	M+2	¹³ C ₁₂ H ³⁵ Cl ₇ O	HpCDF ³
	421.8	357.9	M+4	¹³ C ₁₂ H ³⁵ Cl ₆ ³⁷ Cl O	HpCDF ³
	423.8	360.8	M+2	C ₁₂ H ³⁵ Cl ₆ ³⁷ Cl O ₂	HpCDD
	425.8	362.8	M+4	C ₁₂ H ³⁵ Cl ₅ ³⁷ Cl ₂ O ₂	HpCDD
	435.8	371.9	M+2	¹³ C ₁₂ H ³⁵ Cl ₆ ³⁷ Cl O ₂	HpCDD ³
	437.8	373.9	M+4	¹³ C ₁₂ H ³⁵ Cl ₅ ³⁷ Cl ₂ O ₂	HpCDD ³
	497.7	427.7	M+4	C ₁₂ ³⁵ Cl ₈ ³⁷ Cl ₂	DecaCB ⁷
	479.7	407.8	M+4	C ₁₂ H ³⁵ Cl ₇ ³⁷ Cl ₂ O	NCDPE
	414.0	264.0	M	C ₈ F ₁₆ N	PFTBA ⁶
423.8	360.8	M+2	C ₁₂ ³⁵ Cl ₇ ³⁷ Cl O	HpCDD	
5	441.7	378.8	M+2	C ₁₂ ³⁵ Cl ₆ ³⁷ Cl ₂ O	OCDF

Group	MRM Transition (m/z)		Transition Precursor Species	Elemental composition of Transition Precursor	Substance ²
	Precursor	Product ⁵			
	443.7	380.8	M+4	C ₁₂ ³⁵ Cl ₇ ³⁷ Cl O ₂	OCDF
	457.7	394.8	M+2	C ₁₂ ³⁵ Cl ₆ ³⁷ Cl ₂ O ₂	OCDD
	459.7	396.8	M+4	¹³ C ₁₂ ³⁵ Cl ₇ ³⁷ Cl O ₂	OCDD
	469.8	405.8	M+2	¹³ C ₁₂ ³⁵ Cl ₆ ³⁷ Cl ₂ O ₂	OCDD ³
	471.8	407.8	M+4	C ₁₂ ³⁵ Cl ₈ ³⁷ Cl ₂ O	OCDD ³
	513.7	443.7	M+4	C ₈ F ₁₆ N	DCDPE ⁷
	414.0	264.0	M	C ₁₂ H ³⁵ Cl ₆ ³⁷ Cl O ₂	PFTBA ⁶

¹ Nuclidic masses used:

Transitions obtained from the Shimadzu Environmental Database

² TCDD	=	Tetrachlorodibenzo- <i>p</i> -dioxin	TCDF	=	Tetrachlorodibenzofuran
PeCDD	=	Pentachlorodibenzo- <i>p</i> -dioxin	PeCDF	=	Pentachlorodibenzofuran
HxCDD	=	Hexachlorodibenzo- <i>p</i> -dioxin	HxCDF	=	Hexachlorodibenzofuran
HpCDD	=	Heptachlorodibenzo- <i>p</i> -dioxin	HpCDF	=	Heptachlorodibenzofuran
OCDD	=	Octachlorodibenzo- <i>p</i> -dioxin	OCDF	=	Octachlorodibenzofuran
HxCDPE	=	Hexachlorodiphenyl ether	HpCDPE	=	Heptachlorodiphenyl ether
OCDPE	=	Octachlorodiphenyl ether	NCDPE	=	Nonachlorodiphenyl ether
DCDPE	=	Decachlorodiphenyl ether			

³ Labeled compound

⁴ There is only one transition for ³⁷Cl₄-2,3,7,8-TCDD (cleanup standard).

⁵ Transition products are from the following losses:

CDDs, CDFs	[CO ³⁵ Cl]
PCBs, HxCDPE, HpCDPE, DCDPE	[³⁵ Cl ₂]
OCDPE, NCDPE	[³⁵ Cl ³⁷ Cl]
PFTBA	[C ₃ F ₆]

⁶ PFTBA is used to monitor stability of detector response.

⁷ PCBs should be monitored when sample cleanup has not included a PCB removal step.

Table 9. MRM Transition Product Ion Ratios and QC Limits

Species Monitored.	MRM Transition Precursor m/z (Primary/Secondary)	Transition Product Ion Ratio (%)	QC Limit ($\pm 15\%$)	
			Lower	Upper
Cl ₄ CDD	(M+2)/M	96	82	110
Cl ₄ CDF	(M+2)/M	96	82	110
Cl ₅ CDD	M/(M+2)	79	67	91
Cl ₅ CDF	M/(M+2)	79	67	91
Cl ₆ CDD	(M+4)/(M+2)	65	55	75
Cl ₆ CDF	(M+4)/(M+2)	64	54	74
Cl ₇ CDD	(M+4)/(M+2)	79	67	91
Cl ₇ CDF	(M+4)/(M+2)	80	68	92
Cl ₈ CDD	(M+4)/(M+2)	96	82	110
Cl ₈ CDF	(M+4)/(M+2)	94	80	108

QC limits represent $\pm 15\%$ windows around the MRM transition product ion ratios.

Does not apply to ³⁷Cl₄-2,3,7,8-TCDD (cleanup standard).

Transition product ion ratios are calculated as secondary ion/primary ion.

Table 10. Suggested Sample Quantities to be Extracted for Various Matrices¹

Sample matrix ²	Example	Percent solids	Phase	Quantity extracted
Single-phase				
Aqueous	Drinking water	<1	— ³	1000 mL
	Groundwater			
	Treated wastewater			
Solid	Dry soil	>20	Solid	10 g
	Compost			
	Ash			
Organic	Waste solvent	<1	Organic	10 g
	Waste oil			
	Organic polymer			
Tissue	Fish	—	Organic	10 g
	Human adipose			
Multi-phase				
<i>Liquid/Solid</i>				
Aqueous/Solid	Wet soil	1–30	Solid	10 g
	Untreated effluent			
	Digested municipal sludge			
	Filter cake			
	Paper pulp			
Organic/solid	Industrial sludge	1–100	Both	10 g
	Oily waste			
<i>Liquid/Liquid</i>				
Aqueous/organic	In-process effluent	<1	Organic	10 g
	Untreated effluent			
	Drum waste			
Aqueous/organic/solid	Untreated effluent	>1	Organic & solid	10 g
	Drum waste			

¹ The quantity of sample to be extracted is adjusted to provide 10 g of solids (dry weight). One liter of aqueous samples containing one percent solids will contain 10 grams of solids. For aqueous samples containing greater than one percent solids, a lesser volume is used so that 10 grams of solids (dry weight) will be extracted.

² The sample matrix may be amorphous for some samples. In general, when the CDDs/CDFs are in contact with a multiphase system in which one of the phases is water, they will be preferentially dispersed in or adsorbed on the alternate phase because of their low solubility in water.

³ Aqueous samples are filtered after spiking with the labeled compounds. The filtrate and the materials trapped on the filter are extracted separately, and the extracts are combined for cleanup and analysis.

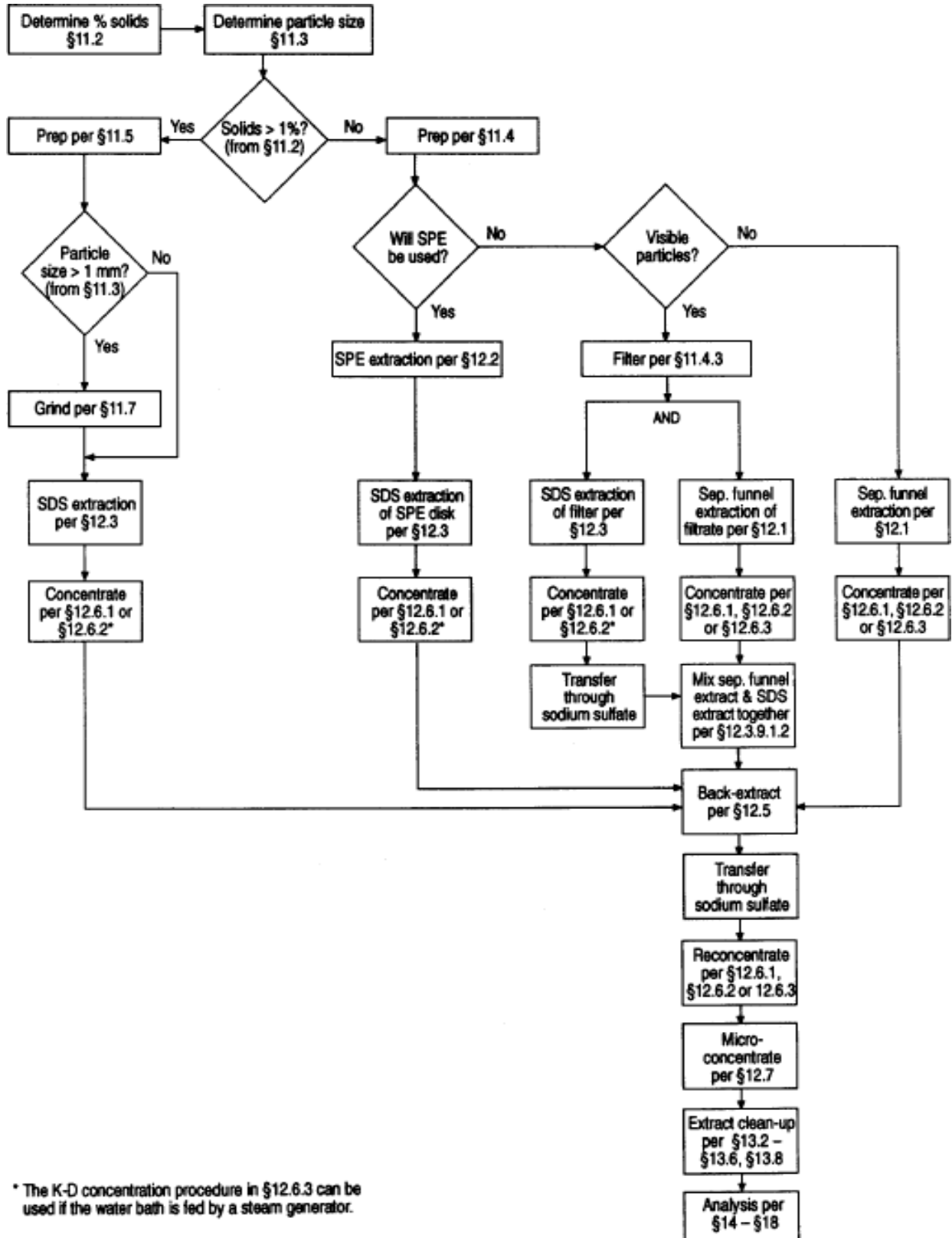

52-028-1A

Figure 1. Flow Chart for Analysis of Aqueous and Solid Samples

w

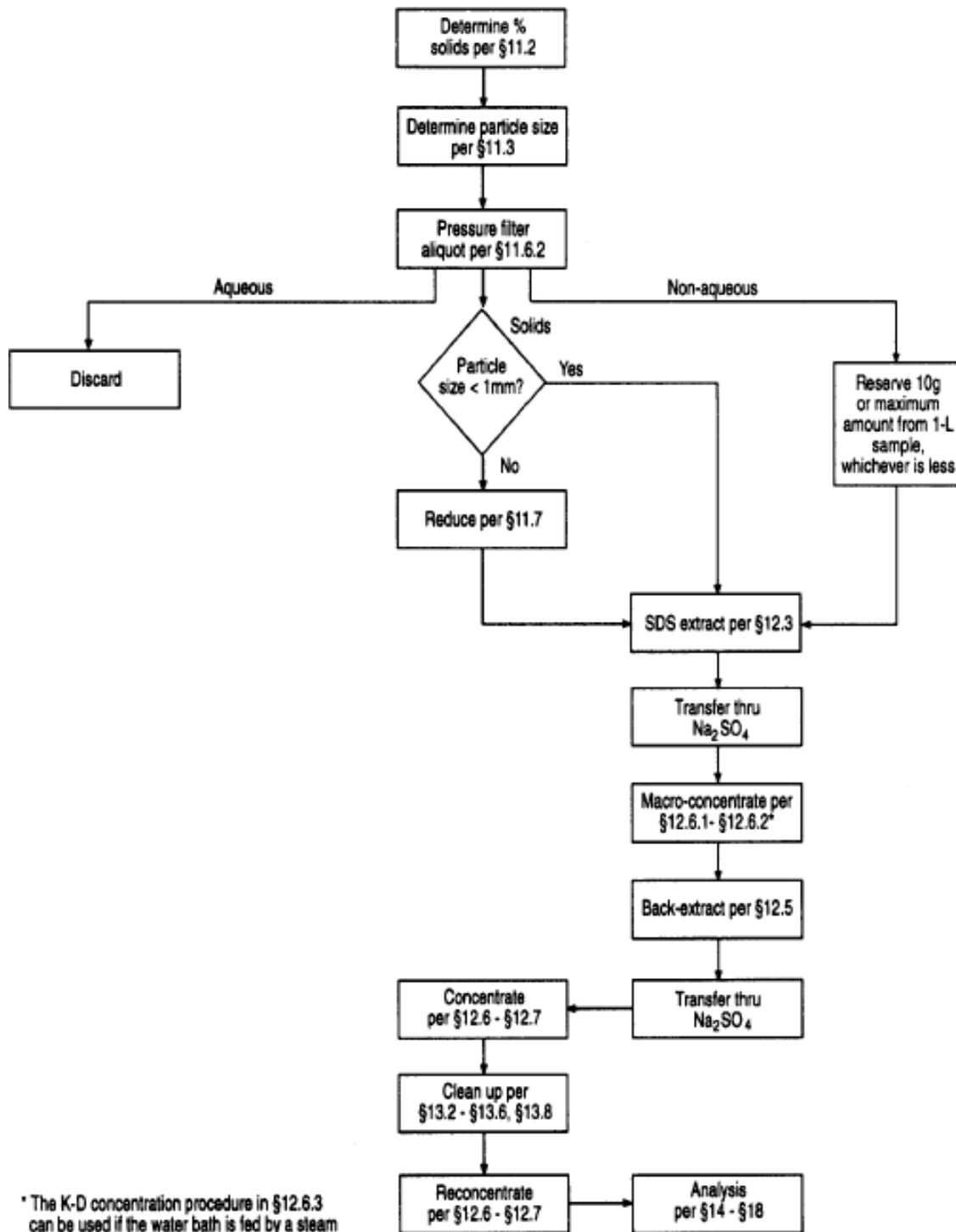
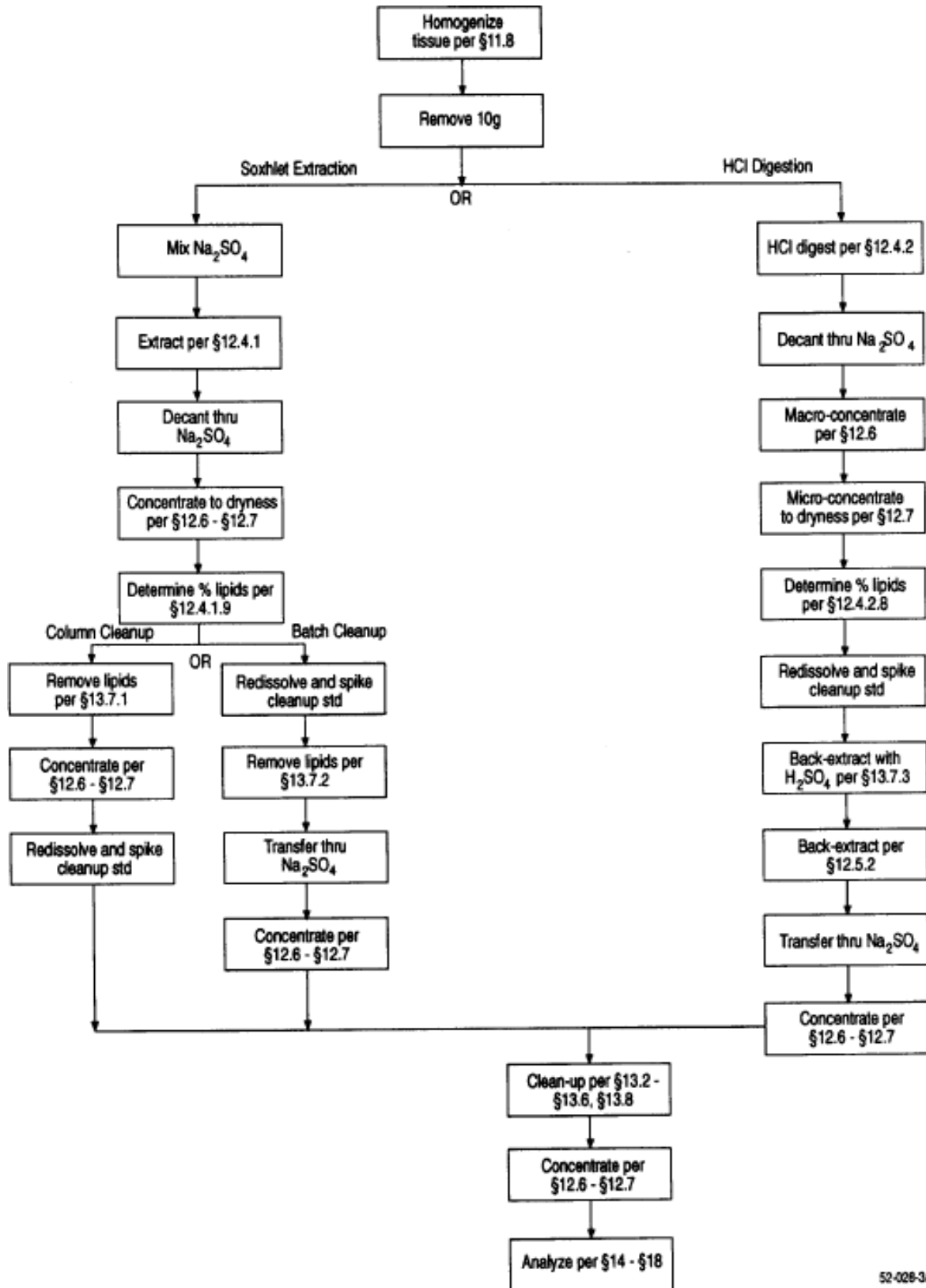

Figure 2. Flow Chart for Analysis of Multi-Phase Samples

52-028-2A



52-028-3A

Figure 3. Flow Chart for Analysis of Tissue Samples

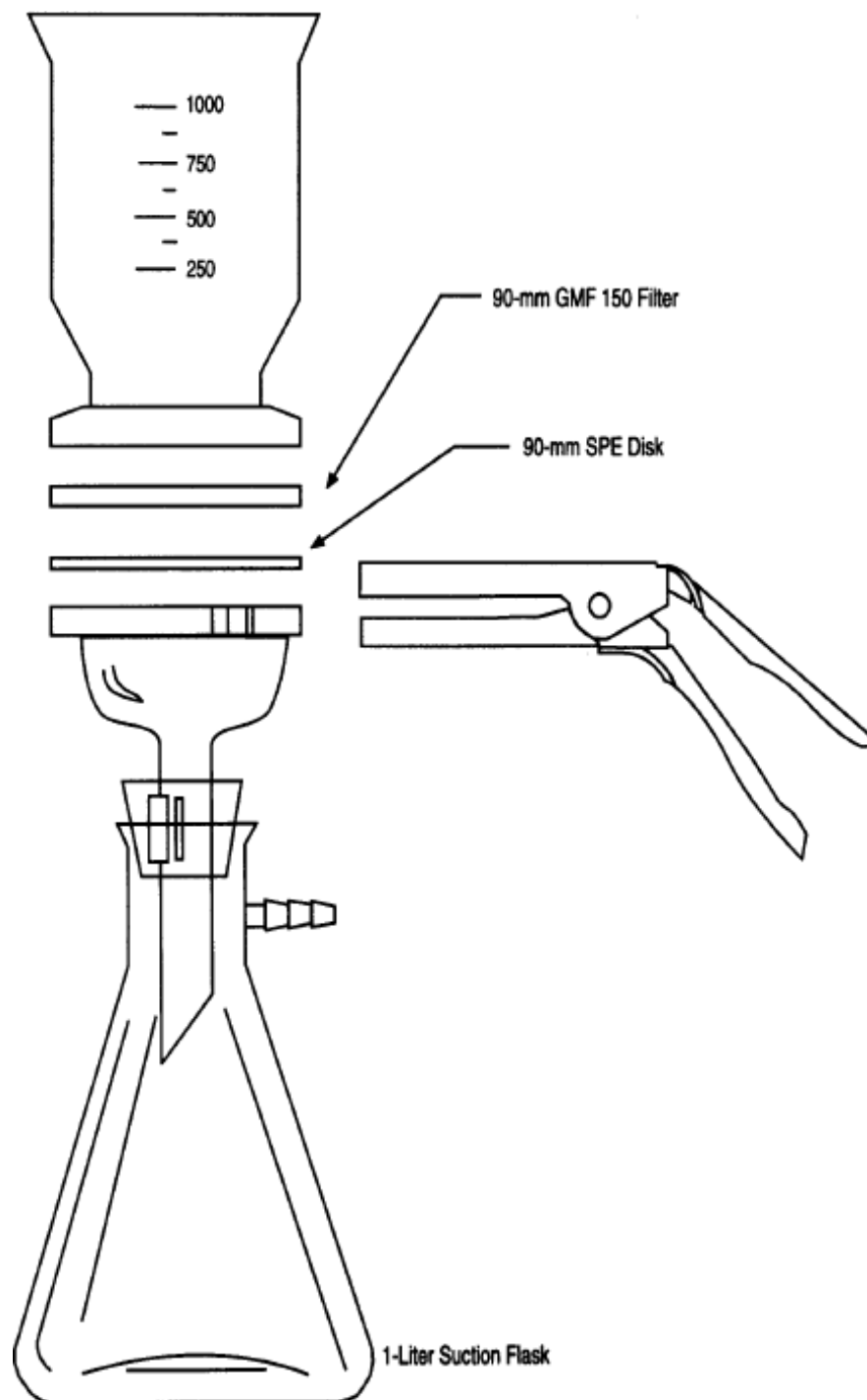
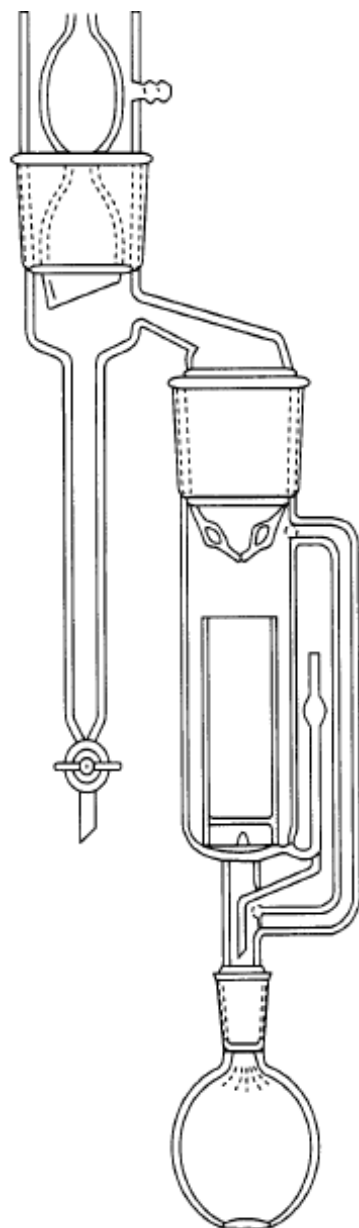

Figure 4. Solid-Phase Extraction Apparatus

52-027-1A



52-027-2A

Figure 5. Soxhlet/Dean-Stark Extractor

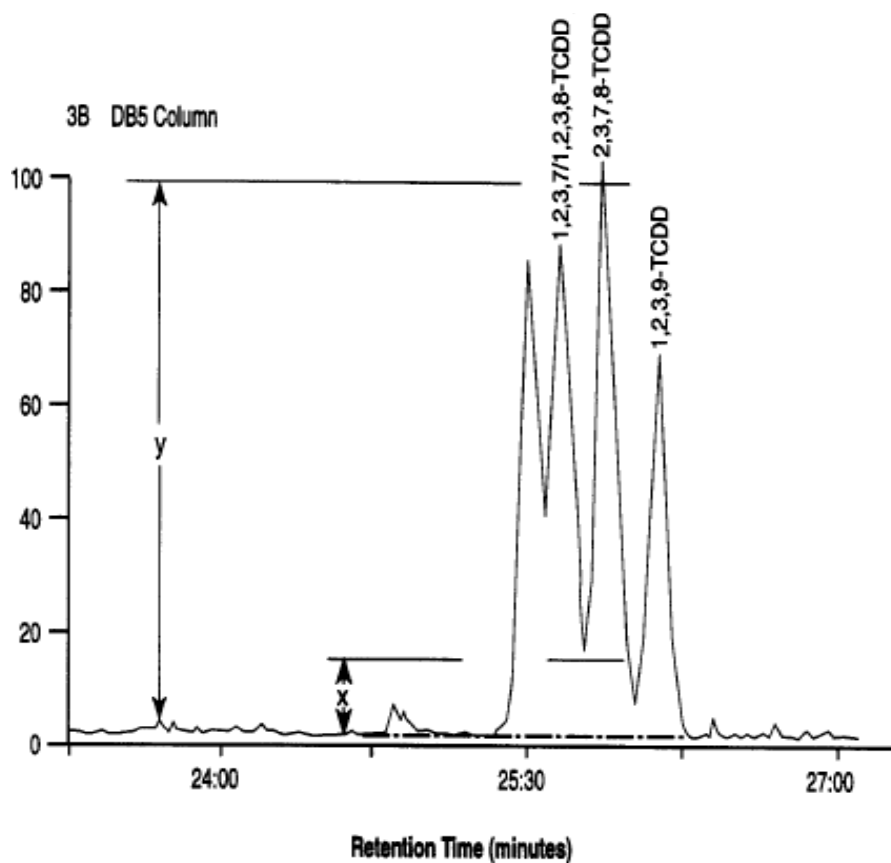

Figure 6. Isomer-Specific Separation of 2,3,7,8-TCDD on DB-5 Column

52-027-03

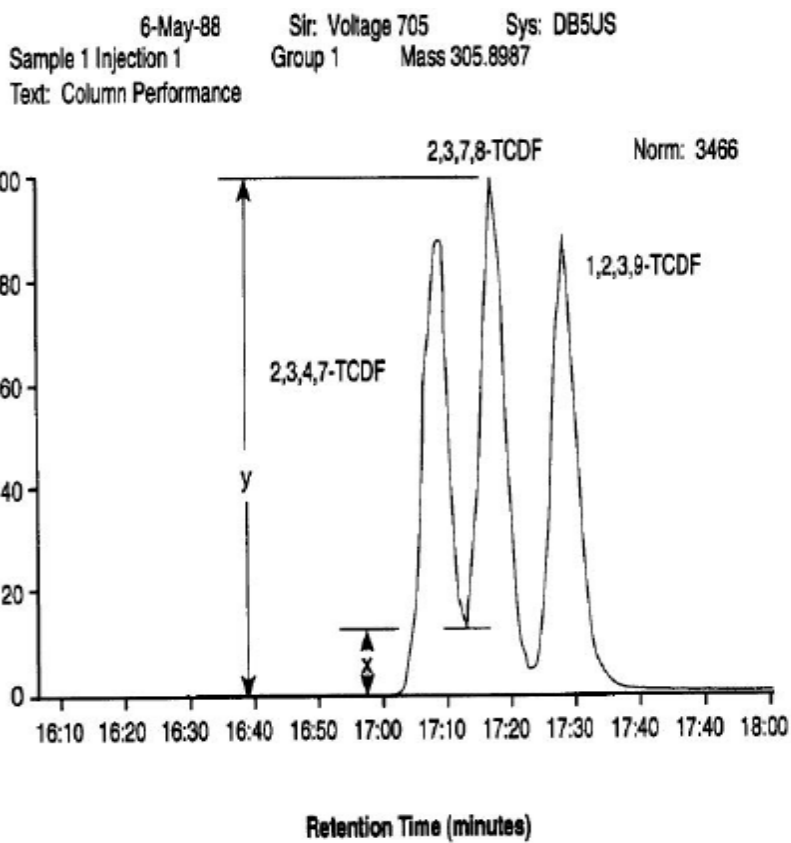

Figure 7. Isomer-Specific Separation of 2,3,7,8-TCDF on DB- 225 Column

52-027-4A

24.0 Glossary of Definitions and Purposes

These definitions and purposes are specific to this method but have been conformed to common usage as much as possible.

24.1 Units of Weight and Measure and Their Abbreviations

24.1.1 Symbols

°C	degrees Celsius
μL	microliter
μm	micrometer
<	less than
>	greater than
%	percent

24.1.2 Alphabetical abbreviations

amp	ampere
cm	centimeter
g	gram
h	hour
ID	inside diameter
in.	inch
L	liter
M	Molecular ion
m	meter
mg	milligram
min	minute
mL	milliliter
mm	millimeter
m/z	mass-to-charge ratio
N	normal; gram molecular weight of solute divided by hydrogen equivalent of solute, per liter of solution
OD	outside diameter
pg	picogram
ppb	part-per-billion
ppm	part-per-million
ppq	part-per-quadrillion
ppt	part-per-trillion
psig	pounds-per-square inch gauge
v/v	volume per unit volume
w/v	weight per unit volume

24.2 Definitions and Acronyms (in Alphabetical Order)

Analyte—A CDD or CDF tested for by this method. The analytes are listed in Table 1.

Calibration Standard (CAL)—A solution prepared from a secondary standard and/or stock solutions and used to calibrate the response of the instrument with respect to analyte concentration.

Calibration Verification Standard (VER)—The mid-point calibration standard (CS3) that is used in to verify calibration. See Table 4.

CDD—Chlorinated Dibenzo-*p*-dioxin—The isomers and congeners of tetra- through octachlorodibenzo-*p*-dioxin.

CDF—Chlorinated Dibenzofuran—The isomers and congeners of tetra- through octachlorodibenzofuran.

CS1, CS2, CS3, CS4, CS5—See Calibration standards and Table 4.

Field Blank—An aliquot of reagent water or other reference matrix that is placed in a sample container in the laboratory or the field, and treated as a sample in all respects, including exposure to sampling site conditions, storage, preservation, and all analytical procedures. The purpose of the field blank is to determine if the field or sample transporting procedures and environments have contaminated the sample.

GC—Gas chromatograph or gas chromatography.

GPC—Gel permeation chromatograph or gel permeation chromatography.

HPLC—High performance liquid chromatograph or high-performance liquid chromatography.

HRGC—High resolution GC.

HRMS—High resolution MS.

IPR—Initial precision and recovery; four aliquots of the diluted PAR standard analyzed to establish the ability to generate acceptable precision and accuracy. An IPR is performed prior to the first time this method is used and any time the method or instrumentation is modified.

K-D—Kuderna-Danish concentrator; a device used to concentrate the analytes in a solvent.

Laboratory Blank—See method blank.

Laboratory Control sample (LCS)—See ongoing precision and recovery standard (OPR).

Laboratory Reagent Blank—See method blank.

May—This action, activity, or procedural step is neither required nor prohibited.

May Not—This action, activity, or procedural step is prohibited.

Method Blank—An aliquot of reagent water that is treated exactly as a sample including exposure to all glassware, equipment, solvents, reagents, internal standards, and surrogates that are used with samples. The method blank is used to determine if analytes or interferences are present in the laboratory environment, the reagents, or the apparatus.

Minimum Level (ML)—The level at which the entire analytical system must give a recognizable signal and acceptable calibration point for the analyte. It is equivalent to the concentration of the lowest calibration standard, assuming that all method-specified sample weights, volumes, and cleanup procedures have been employed.

MRM — Multiple Reaction Monitoring is a targeted mass spectrometry technique, used with tandem mass spectrometers, in which a target ion corresponding to the analyte of interest (called a precursor) is selected in the first MS stage, fragmented in the second stage into product ions which are then detected by the third stage MS. The MRM technique monitors the response of the precursor to product transition.

MS—Mass spectrometer or mass spectrometry.

Must—This action, activity, or procedural step is required.

OPR—Ongoing precision and recovery standard (OPR); a laboratory blank spiked with known quantities of analytes. The OPR is analyzed exactly like a sample. Its purpose is to assure that the results produced by the laboratory remain within the limits specified in this method for precision and recovery.

PAR—Precision and recovery standard; secondary standard that is diluted and spiked to form the IPR and OPR.

Preparation Blank—See method blank.

Primary Dilution Standard—A solution containing the specified analytes that is purchased or prepared from stock solutions and diluted as needed to prepare calibration solutions and other solutions.

Quality Control Check Sample (QCS)—A sample containing all or a subset of the analytes at known concentrations. The QCS is obtained from a source external to the laboratory or is prepared from a source of standards different from the source of calibration standards. It is used to check laboratory performance with test materials prepared external to the normal preparation process.

Reagent Water—Water demonstrated to be free from the analytes of interest and potentially interfering substances at the method detection limit for the analyte.

Relative Standard Deviation (RSD)—The standard deviation times 100 divided by the mean. Also termed "coefficient of variation."

RF—Response factor. See Section 10.6.1.

RR—Relative response. See Section 10.5.2.

RSD—See relative standard deviation.

SDS—Soxhlet/Dean-Stark extractor; an extraction device applied to the extraction of solid and semi-solid materials (Reference 7).

Should—This action, activity, or procedural step is suggested but not required.

SPE—Solid-phase extraction; an extraction technique in which an analyte is extracted from an aqueous sample by passage over or through a material capable of reversibly adsorbing the analyte. Also termed liquid-solid extraction.

Stock Solution—A solution containing an analyte that is prepared using a reference material traceable to EPA, the National Institute of Science and Technology (NIST), or a source that will attest to the purity and authenticity of the reference material.

TCDD—Tetrachlorodibenzo-p-dioxin.

TCDF—Tetrachlorodibenzofuran.

VER—See calibration verification standard.